

Rosicrucian Digest

June 1976 • 50c



Featuring:

- **Mysticism**
- **Science**
- **The Arts**

**Kirlian Photography—
A Tool for Psychic Research?**

Transcending the Ego

Is God an Energy?

The Secret Doctrines of Jesus

A Book That Dares To Tell

by H. Spencer Lewis, Ph.D.

Dr. H. Spencer Lewis, after years of extensive research and journeys to Europe, the Far East, the Holy Land, and Egypt, has fearlessly disclosed in this book these hidden doctrines of Jesus. Beautifully bound and illustrated and stamped in gold.

Price **\$5.75**

Foreign Currency Equivalents
£3.20 AM.20 NZ\$ 35
¥3.25 47.25 65.00

The Mystical Life of Jesus

by H. Spencer Lewis, Ph.D.

This book is a full account of the birth, youth, early manhood, and later periods of Jesus' life, containing the story of his activities in the time not mentioned in the Gospel accounts. The facts relating to the Virgin Birth, crucifixion, resurrection, and ascension will astound and inspire you. The book contains fully explained mystical symbols, original photographs, and an unusual portrait of Jesus. Beautifully bound and stamped in gold.

Foreign Currency Equivalents
£3.20 AM.20 NZ\$ 35
¥3.25 47.25 65.00

Price **\$5.75**

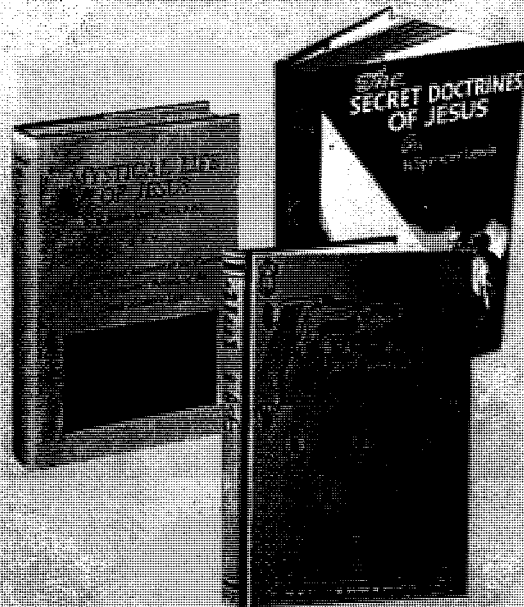

The Symbolic Prophecy of the Great Pyramid

by H. Spencer Lewis, Ph.D.

The World's Greatest Mystery!

The Great Pyramid stands as a monument to the learning and achievements of the ancients. For centuries its secrets were cloistered in stone—now they stand revealed. You will be amazed at the pyramid's scientific construction and at the tremendous knowledge of its mysterious builders. Within the pages of this enlightening book are the answers to many entrancing questions. Never before in a book priced within the reach of every reader have the history, vast wisdom, and prophecies of the Great Pyramid been given. The book is well bound and contains important charts and illustrations.

Foreign Currency Equivalents
£3.20 AM.20 NZ\$ 35
¥3.25 47.25 65.00

Price **\$5.25**

Send your order to:

California residents please add 6% for sales tax

THE ROSICRUCIAN SUPPLY BUREAU

Rosicrucian Park • San Jose • California 95191 • U.S.A.



Does Consciousness Survive Death?

Is immortality an obsolete tradition? Will the advance of science prove — or disprove — the afterlife? As music ceases when the instrument is done, is the *self snuffed out* when the body is no more? Can the consciousness realize itself after death? Orthodoxy stands at the crossroads. Heaven and hell as places — and torment after death — will be challenged by the facts of the space age. What is truly immortal about man? It is time for thinking men and women to

learn the *truth* of their cosmic relationships.

ACCEPT THIS FREE BOOK

Let The Rosicrucians (not a religion), a world-wide fraternity, reveal to you what inquiring free thinkers have learned about self. You will be no less a vital power because you discover the truth about yourself. Write today for the *free book*, the *Mastery of Life*. It is a frank discussion about the *real you*. Use coupon below or write: Scribe S.P.C.-3

**The
ROSICRUCIANS**
(AMORC)
San Jose, California 95191, U.S.A.

Scribe S.P.C.-3
Rosicrucian Order, AMORC
San Jose, California 95191, U.S.A.

The facts about life and self interest me. Please send me the free book, the *Mastery of Life*.

Name

Address

City State Zip

ROSICRUCIAN DIGEST

Published Monthly by the Supreme Council
of

THE ROSICRUCIAN ORDER
A M O R C

Rosicrucian Park, San Jose, California 95191

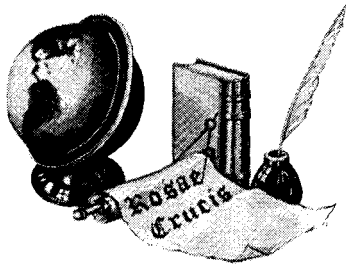

COVERS THE WORLD



Subscription to the **Rosicrucian Digest**, \$5.00* per year. Single copies 50 cents. Address: ROSICRUCIAN DIGEST, Rosicrucian Park, San Jose, California 95191, U.S.A.

Entered as Second-Class Matter at the Post Office at San Jose, California, under Section 1103 of the U. S. Postal Act of October 3, 1917. Second-Class postage paid at San Jose, California.

Changes of address must reach us by the first of the month preceding date of issue.

Statements made in this publication are not the official expression of the organization or its officers, unless declared to be official communications.

—
*Foreign Currency Equivalents
£2.75 A\$4.00 NZ\$5.00
¥3.35 ₡6.25 R4.35
—



Robin M. Thompson, Editor

**OFFICIAL MAGAZINE OF THE
WORLDWIDE ROSICRUCIAN ORDER**

The Purpose of the Rosicrucian Order

The Rosicrucian Order, which exists throughout the world, is a nonsectarian fraternal body of men and women devoted to the investigation, study, and practical application of natural and spiritual laws. The purpose of the organization is to enable everyone to live in harmony with the creative, constructive cosmic forces for the attainment of health, happiness, and peace. The Order is internationally known as the Ancient Mystical Order Rosae Crucis and, in America and all other lands, constitutes the only form of Rosicrucian activities united in one body. The A.M.O.R.C. (an abbreviation) does not sell its teachings. It gives them freely to affiliated members, together with many other benefits. For complete information about the benefits and advantages of Rosicrucian affiliation write a letter to the address below and ask for the free book, **The Mastery of Life**.

Address Scribe S. P. C.

Rosicrucian Order, AMORC
San Jose, California 95191, U.S.A.
(Cable Address: "AMORCO")

CONTENTS

Kirlian Photography (See page 24)	Cover
World Assembly of Grand Lodge Officers (Frontispiece)	3
Thought of the Month: Arousing Inspiration	4
Thanks for the Compliment	7
Transcending the Ego	8
Around Africa—The Ancient Egyptian Way	12
Medifocus: Mr. Suharto, President, Indonesia	14
The Celestial Sanctum: Necessity	15
The Universal Conversation	17
The Spoofer	18
Is God An Energy?	20
Mindquest: Kirlian Photography—A Tool for Psychic Research?	22
The Dangers of Bigness	25
Up and Down Life's Ladder	28
Cosmic Politics	31
Rosicrucian Activities Around the World	35
The Palace of Versailles (Illustration)	37
Ancient Jericho (Illustration)	38

WORLD ASSEMBLY OF GRAND LODGE OFFICERS ▶

This assembly, in joint session with the Supreme Grand Lodge Officers, was held recently at Rosicrucian Park, San Jose. For further explanation and identity of the personalities, see page 35.

(Photo by AMORC)

Volume LIV June, 1976 No. 6

Copyright, 1976, by the Supreme Grand Lodge of AMORC, Inc. All rights reserved.



THOUGHT OF THE MONTH

By THE IMPERATOR

AROUSING INSPIRATION

INSPIRATION PROVIDES an intellectual and emotional stimulus. In the intellectual sense, inspiration takes the form of an idea which the mind images, producing an emotional satisfaction. There are many ideas which can be recollected as past experiences and which are associated with varying degrees of pleasure. However, such recollections cannot be said to be inspiration. The uniqueness of an inspirational idea is its apparent originality; it is that which has not been objectively perceived in the form in which it is realized.

Personal motivation is another important element of inspiration. When one is inspired he is immediately compelled to action. In other words, there is a desire to objectify the idea, to bring it into such reality that it has an external existence. Consequently, the very obvious value of inspiration lies in its *creative incentive*. No one who has ever been inspired remains passive. An inspirational idea does not remain dormant in the consciousness.

If inspiration has such a practical value, at least in bringing forth that which may not have existed previously, then how is it attained? Inspiration is related to personal idealism. Each individual has an admiration for certain specific qualities or functions. This goal may be something which he has never personally attained because he believed he lacked the adequacy to achieve it. Or again, it may be an effort put forth that one believes to be inferior but which he would like to perfect. Whatever is then subsequently experienced as being associated in any manner with—or as representing achievement in connection with—such idealism, inspires our courage and determination to emulate the inspira-

tion. Many persons have converted failure into success by witnessing how another conquered the same obstacles.

Intuition and inspiration are psychically related. Inspiration is engendered whenever we intuit something or whenever there flashes into our consciousness an idea which has great clarity—one which we accept as reality or truth. Inspiration therefore prompts us to act in order to verify the intuitive idea; in other words, the intuitive flash is dynamic, and its dynamism is the inspiration.

Intuition—or insight, as it is technically termed by psychologists—is the result of the working of the subconscious mind which combines and reorganizes latent thoughts into new combinations of harmonious relationships. What gives these intuitive thoughts their efficacy is the greater perspicuity which they often have over the conclusions of our reason. More simply, our reason cannot oppose these intuitive thoughts at the time. The apparent perfection of such ideas seems to transcend any logical objection that we may have, thus arousing the *emotion* of intuition which we relate as inspiration.

Ideas

There is no truly virginal intuitive idea. What flashes suddenly into consciousness, even if it seems not to have been labored over, is nevertheless related to ideas originating in our perception or imagination of the past. Such ideas may have lain dormant in the subconscious for an indeterminate time. Experiences one has that contain an element associated with these dormant ideas become related to these ideas in the subconscious. The idea aroused from the experience acts as a trigger—bringing together the dormant elements in the consciousness much as

*The
Rosicrucian
Digest
June
1976*

the combining action of a catalyst upon diverse chemical elements. Simply, the process is a shuffling about in the subconscious of previously implanted ideas until they represent an agreement. It is this unity of ideas then that has sufficient force to penetrate into the conscious mind as a "hunch," or intuitive flash.

All inspiration is not involuntary. Often serious contemplation, sheer reasoning, and logic in approaching a problem will suddenly induce the inspiration, the apparent solution. If, after a time, one is convinced that he has exhausted a rational approach to a problem, then the effort should be at least temporarily abandoned. Persistent thinking over a long period of time merely produces fatigue so that one then experiences nothing but a repetition of the same thoughts. Dismissal, however places them in the subconscious where they can be activated at a future time into an intuitive impression with its accompanying inspiration.

Reason alone is not the sole provoker of inspiration. Emotional gratification can also provide the release of a chain of thoughts from which inspiration will emerge. That which may appeal to the higher emotions and sentiments, those having an effect on the intellect, will often inspire the individual with a simultaneous releasing of an unrelated idea of great clarity and force suggesting achievement in some endeavor.

For example, it is related that George Eastman of Eastman Kodak fame had long sought a substitute for the glass which was used for negatives in photography. Such glass negatives were fragile and cumbersome as well as expensive. Mr. Eastman knew that an alternative was necessary but what could it be? Mr. Eastman enjoyed music, and on one occasion, it is related, was attending a symphony concert. While listening to the music in a relaxed state of mind, the idea for an alternative to the glass negative suddenly flashed into his consciousness. This idea resulted in his producing paper film treated with an emulsion as a negative. Such unbreakable material could be put in compact, efficient, and economical rolls. His intuitive idea and the inspiration it aroused resulted in the huge establishment of the Eastman Kodak concern which is now world-wide in extent.

It is further related that Eastman was so appreciative for what music had done for him as well as the revelation and creative idea it inspired, that he eventually sponsored the now world-famous Eastman School of Music. It was George Eastman's hope that music might inspire those attending the school and the concerts and bring forth ideas as equally important as his—contributing to the welfare of humanity.

Everyone is not equally creative. We may not have the particular skill or talent to execute an idea, to bring what comes to mind into reality. However, a person can be inspired by observing something brought into existence by others, which may suggest to him a valuable improvement or something quite different.

Inspiration

Many inventions or unique services are not the original concept of the engineer, scientist, or artist who finally materialize them. The creations are often the consequence of direct suggestions made by other persons who have the *inspiration* but lack the capability of bringing such into reality.

To be inspired one must keep his special interests alive. He should think about them, see examples of them, talk about them. But it is not necessary for him to continually labor over them, keeping them constantly in mind until they become annoying and fatiguing. However, one should dwell on them as long as it provides pleasure. This then plants associated ideas in the subconscious. At some time what may be observed will become the catalyst, the combining element that will bring these myriad ideas together in the form of a concrete inspiration.

One who is artistically inclined, for example, should make a custom of visiting museums of art and antiquities. If he actually paints or sculpts, even as an amateur, then what he sees that may be related to his interest may result someday in inspiring an idea of creative value. The same may be said of those who have interests in mechanics, science, and literature, or in any specialized field of interest. To use an analogy: we may

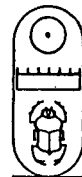

say that one pole or polarity exists in the recesses of the individual's mind, while another exists in something that he will observe or experience. Then there is a sudden mutual attraction between these poles. The external stimulus arouses the internal from which flows the insight or inspiration.

Should the lower emotions and passions dominate the consciousness, they can be-

come a barrier to the external force necessary to act or arouse inspiration. For example, one who is possessed by hate, envy, and jealousy is rarely a recipient of genuine inspiration. There is a feeling of euphoria, a sense of well-being and of personal goodness experienced in real inspiration which never accompanies ideas of malice and destruction. Δ



Spring Street

Photography and Printmaking

The Rosicrucian Art Gallery recently presented its annual exhibition of photography and printmaking by San Jose's Light and Shadow Club. This fascinating collection consisted of both black & white and color prints with varying techniques used in processing the film. Among the excellent photos, Bert Donlon's "Spring Street" is a very unique example of printmaking. The actual size of this exhibit is fifteen inches high and eighty inches wide. The print "Spring Street" was processed on a dark-room floor, developing chemicals were applied with a mop, and the print hung to dry on a clothes line. This is just one example of the creativity and involvement of photography.

***The
Rosicrucian
Digest
June
1976***

Thanks for The Compliment

by David Gunston

"I CAN LIVE for two months on a good compliment," said Mark Twain, and most of us warm to his remark. Indeed it might be argued, the more we, ourselves, lack good compliments, the more we appreciate his sentiment.

For it is a deep, basic human need to receive praise, even applause. If indeed "all the world's a stage," then truly all its actors respond to a favourable reception—and lose self-confidence if it is withheld—just as much as do those in the professional world of the theatre.

As Fulton Oursler reminds us: "No one, great or obscure, is untouched by genuine appreciation. We all have a double necessity: to be commended and to know how to commend." He suggests that it is no real compliment to praise a man for some obvious attainment, but instead, a discerning, original approach is preferable. Although it is always refreshing to receive a compliment, even an indirect one, on some attribute, gift, or skill we did not really think much of in ourselves, even the cleverest people at times need to be complimented on their acknowledged best qualities. Otherwise, we may well have increasing and nagging spells of self-doubt.

At its lowest level, the bestowing of compliments encourages good thoughts

and a good attitude toward other people. In Oscar Wilde's witticism this is made amusingly plain: "It is a great mistake for men to give up paying compliments, for when they give up saying what is charming, they give up thinking what is charming."

At its highest level, the giving of words of praise brings spiritual magic to both giver and receiver. This must be true in everyone's experience, yet how often do we act as if it were not? "Correction does much," says Goethe, "but encouragement does more." "Both praise and criticism are reinforcing," counsels Jo Coudert, "but praise reinforces good traits, criticism bad traits. Criticism produces defensiveness, and no one acts well out of defensiveness: he is rattled, shaken, and hurt. Criticism causes the personality to shrink, to be diminished, and not only the personality of its target, but of its deliverer as well."

She adds: "While criticism is toxic, praise, in contrast, is enhancing. It is an expression of generous feelings which expand the area of warmth in the giver and gives rise to confidence in the recipient."

"What people want," declares William Lyon Phelps, "is a little attention as human beings." This is so primal and simple a truth that it is very often overlooked completely. We are all of us quick to complain and criticise, but usually slow to offer the reverse side of the coin when occasion demands. "Be quick to praise," advised Bernard Baruch. "People like to praise those who praise them. Be sincere in doing this."

(continued on page 34)

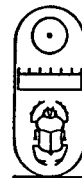

Transcending

The Ego

by Thomas E. Parker, Ph.D.

MANY SUCCESSFUL PEOPLE, having achieved most or all of the goals they set for themselves, find that they are still not happy. Something does not feel all right. After running out of goals, those whose lives become frustrated and then intolerable sometimes feel driven to seek outside help. They want to know, "How come things aren't all right?"

These people are suffering from a collapse of meaning. This loss is connected with the ego, the experience of a soul in a body. The soul, coming from the source of true consciousness, enters the body with such tremendous force that attention is riveted upon the body and the external world, thereby turning its back, so to speak, on the universal source of energy.

As soon as the ego begins to form, it sets up a basic dualism: the sense of I-ness and the sense of being separated from other things. We might speak of the *me* and the *not-me*. Those things that are related to the ego become a part of consciousness. Those things that are not related to the ego remain—or become—unconscious. This basic dualism separates man from his own nature, his own instinctual side, and separates him from his fellowman.

People who have lost meaning in life have in some way or other *inflated* the ego. At some point an inevitable deflation occurs, and with it a loss of meaning. These people now come face-to-face with the real problem; namely, that true meaning comes from being connected with something greater than their ego consciousness. Unless they are reconnected with the Self—that is, the reflection within us of the Infinite—they will never find the meaning they are looking for.

To reexperience the Self or soul, the flow of energy must be *reversed*. First, the ego must be transcended. We must overcome the delusion that we do things, that we are the doer, or the cause, or the creator. The ego thinks things like: "I am tall. I am short. I am fat. I am an American. I am a Chinese. I am a Hindu." The experience of the Self would be, "I am experiencing tallness, or heaviness, or fatness, but I am not that." One observes and experiences these qualities but does not identify with them.

It is not the ego that is the root of our alienation from Self but *our identification* with the ego. In fact, the ego is our salvation. When one accumulates the necessary energy, one can transcend the ego. The paradox is that one has to strengthen the ego to be able to overcome it. We have to have a strong sense of ourselves to be able to see that we are really a part of something else. A strong ego means much energy is available.

For many of us energy is drained in unconscious ways. In the unconscious, different parts of ourselves are pulled in different directions. This unconscious pulling in opposite directions uses up a lot of energy. Part of us wants to do this; part of us wants to do that. This tug-of-war is the inescapable condition of life in that conflicts arise constantly. If these conflicts were resolved, the energy used in the conflict could be available for other purposes.

*The
Rosicrucian
Digest
June
1976*

Even more important than conflicts are the energy-draining complexes. A complex gets formed when we push things out of our usual state of consciousness. We reject certain experiences by trying to shove them out of consciousness. When they go, they take a certain amount of energy with them. We have to use more energy to hold them out of consciousness.

Preliminary to transcending the ego, therefore, we must expand our consciousness to include some of the previously repressed and undeveloped parts of ourselves so that the energy from them becomes available to consciousness. This energy has to be controlled, however. It is not just energy that is bouncing around. Some people can be frantically active but they are not really directing that energy. They have to choose in what way to direct it, whether toward their own happiness or toward just doing things, which may be running away from the problem of meaning in life. If one has a strong ego, he may use that energy to overcome the limitations of the ego.

Many times much energy is tied up in defending the ego, that is, trying to maintain a view of oneself that is not in accord with one's real nature. For example, if a person is unable to cope with

the world on a daily basis, he is defensive. He wants to see himself, perhaps, as being very competent, and when he is not competent he finds some way to defend himself. He will say, "It's those other people. Look how badly people treat me. No wonder I have troubles." Much of his energy is tied up in this way.

A Weak Ego

The process of disidentifying with the ego takes energy. The *will* is the energy available to the ego. This energy becomes available whenever an unconscious content becomes conscious. Therefore, if one is mostly unconscious of himself, that is, if he has a weak ego, he does not have much energy available to use the way he wants. What is really meant by a weak ego is that too much of the person is unconscious. In this state, much of the unconscious content will be in opposition to the conscious adaptation. One result is a lowered amount of energy available to the ego.

It is the essential task of each of us to make the ego strong in order to reduce the amount of conflict and difficulties that exist in the unconscious. Without the ego consciousness, with all of its emotions, all of its difficulties, and all of its joys, there is no duality, no separateness,

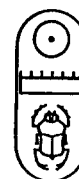
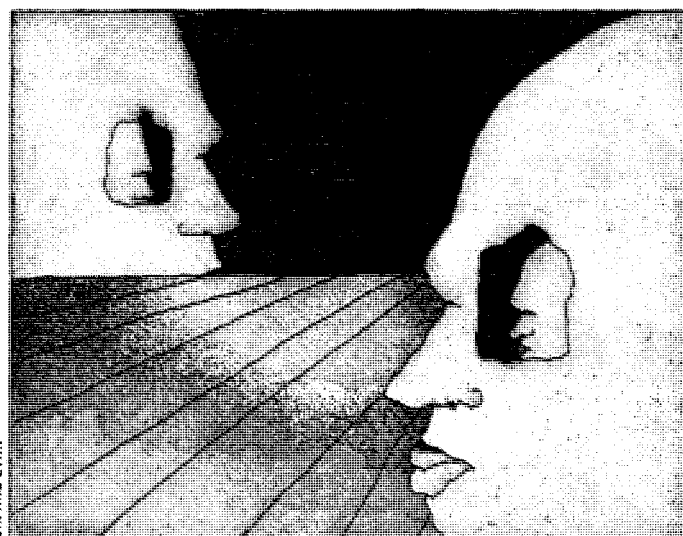

no agony. But it is only through the dualism of the ego that transcendence becomes possible. The most important use of a strong will, therefore, is to transcend its master, the ego.

The formula may be put something like this: Ego strength leads to a strong will, making a lot of energy available. This energy gives one the power to concentrate. The power to concentrate allows one to control the mind. This state in turn allows one to break the delusion of ego-consciousness duality, with its sense of I-ness and separateness. At this point, one may discover one's true nature through getting in touch with those forces that are greater than ego consciousness.

Most people want to find a way of getting beyond the narrow confines of their individual lives. Some of them begin to look for scientific methods of getting in touch with their true nature. The most scientific methods have to do with meditation.

Meditation

To meditate means to concentrate on the infinite. Concentration means to put attention in one place. If your attention is in two places, you are not concentrating. Most of us need help in learning to concentrate. We have to have techniques; we have to have ways of doing it. For analogy, if you want to make apple cider, it does not do any good to bake apples. You can bake them many times, but you will never get any apple cider. The proper way to make cider is to press the apples. In meditation you have to use the right techniques. If you do, you will get results, and you get them scientifically.

In meditation, the attempt is made to cut off the outward flow of energy so that eventually we can *reverse* this flow. Consciousness goes wherever energy goes. If we move, we send energy into the body. That is why one of the first rules of meditation is to sit still. As long as there is any movement, energy goes there. Consciousness follows it into the phenomenal world, and the person trying to meditate will be attached to this consciousness.

When you can stop the energy from going into the body by sitting very still so that the energy does not go into the muscles, and when you become free of

your thoughts, concentrate until you have a single thought. All of the energy will be concentrated in that single thought. This process is what meditation is all about—*withdrawing* the energy from the body, calming the waves of the mind, and finally, with the energy that is at last available, concentrating on the source of all being. At this point we begin to see that we are not the body, because we can observe it. We can see thoughts coming and going. We become non-attached to them. We realize: "No, I am not that body. I am not that mind. They are not really what I am, because I am observing them."

People sometimes misunderstand meditation. They think that once they begin to meditate all of their problems are behind them. That is not true. Often meditation brings problems to the surface to be made conscious and worked out. Nevertheless, meditation brings with it a sense of peace, joy, and ultimately, bliss. There are many techniques available. We will be drawn to the techniques and the way that is right for us.

Transcending the ego through meditation is a concept many people avoid. They think that becoming nonattached to the body means not taking responsibility for it. Some claim to be free of the body long before they even come close to it. Others have attempted the process of nonattachment in a kind of leapfrog fashion, without going through the necessary steps. Still others are filled with guilt, anxieties, and inadequacies, but every limitation we have is self-imposed, either by a conscious or subconscious idea of limitation.

When people get hold of the limiting ideas they place upon themselves and change them, the world changes. It is a wonderful experience when we can tell ourselves: "I don't know what has happened. I have friends, and I never had friends before." We have changed some kind of limitation inside ourselves. It takes work and a good deal of available energy, but this is the beginning of getting over those self-imposed limitations. When the identification with the ego is broken, we can come to a higher state of consciousness. An experience of enlightenment can ensue.

The experience of enlightenment is not always a pleasant one. The expansion of

consciousness may seem frightening because it is so unfamiliar. However, the person who has transcended the ego does not encounter this kind of experience. His consciousness is not limited. Some who have had this experience describe it as being a vast circle of consciousness in which the body is only a point bathed in light. There is no distance; the center is everywhere.

Only a strong ego that corresponds to the way the universe exists can transcend its duality. Strengthening the ego, however, is a paradox. The number of com-

plexes is essentially infinite and, no matter how many you solve, there are endless more waiting to be solved. It is an unceasing process. One must spend a great deal of time at it before he can transcend ego consciousness. A person must be willing to settle for the process itself, have faith in it, and follow techniques of meditation.

The full meaning of life becomes possible for those who transcend the ego and, in doing so, reunite the little bubble of individual Self with the large cosmic sea of soul that resides everywhere. △



Our present-day Olympic Games carry on only a part of the old Greek tradition—that involving athletic competition between the world's physically superb men and women. Although the original Olympian-type gatherings were the occasions of interstate games, basically they were **holydays** according to philosopher-historian Will Durant. It was the good fortune of Greece to have a religion eventually humane enough to associate itself joyfully and creatively with art, poetry, music, and finally, morality. These Olympian traditions are at present also carried on at universal gatherings such as the summer sessions of Rose-Croix University held at Rosicrucian Park, San Jose.

Coming to harmonious terms with our duality of self often brings with it a profoundly victorious feeling that might well have been experienced by one of the contestants of the Pythian mysteries held at Delphi, or the Olympic mysteries in Elis. Often set apart from the vast audience of humanity, the ancient as well as the modern mystic is literally and physically besieged by urges to **create something unique**. What is of primary importance now is not so much a matter of **what** is created but that **something is** created. If sufficient preparation has been made along mental, spiritual, and physical lines with all in relative harmonium, then the resulting creation will be a work of art. It will be both beautiful and beneficial to mankind.

For many of us, this satisfying creative drive tends to manifest itself in the very area that we find most awkward or decidedly lacking in our makeup. However, the Inner Self provides the burning desire that helps neophyte-contestants to fashion their own unique genius with loving patience and hard work. We are much like a sculptor who has a vision of the statue within the uncut stone; we must labor to see our work of art unfold! However, in the dawning of a new day upon an inner Pythian festival, we shall attain that coveted Laurel wreath. We shall in **deed** become that rare baccalaureate from Delphi.

— June Schaa, F. R. C.

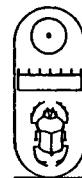

Around Africa

The Ancient Egyptian Way

by Pierrette Posmowski

WERE THE SAILORS of ancient Egypt able to circumnavigate Africa? Yes, according to two Frenchmen, a former submariner and a naval architect, who believe ships capable of such a long voyage existed over 3500 years ago.

André Gil-Artagnan, who served in submarines, and René de Tauriac, the ship designer, hope to test their belief successfully by sailing a replica of an ancient Egyptian vessel all around Africa. Their intention is to sail from the Red Sea down the east coast, rounding the Cape of Good Hope, then up the west coast, through the Straits of Gibraltar, and so back to Egypt.

According to ancient historians, Phoenician seamen in the service of Pharaoh Necho II (reigned 609-594 B.C.) took this route, returning to Egypt three years later. And according to Gil-Artagnan and de Tauriac, Egyptian ship design was already up to the challenge of such a long voyage over 1000 years before Necho.

For those first seamen who made the trip around Africa, the voyage was a hazardous undertaking involving unknown seas, an inhospitable coast and harsh weather. About a century and a half later, the Greek historian Herodotus gave this account of their nautical pioneering:

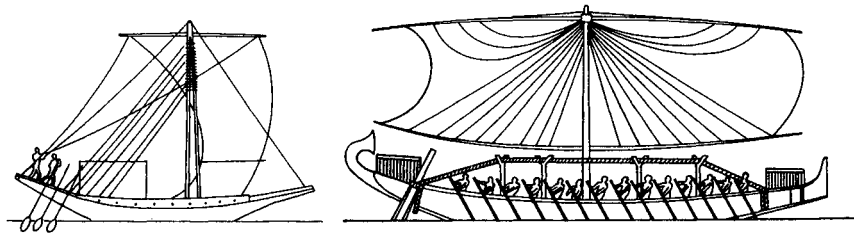

*The
Rosicrucian
Digest
June
1976*

The boat used by Egyptians about 2500 B.C. (left) could use its sail only if the wind came from behind. One thousand years later design had advanced enabling Egyptians to make long voyages using winds coming from different directions.

“As for Libya (ancient Greek name for Africa), we know it to be washed on all sides by the sea, except where it is attached to Asia. This discovery was first made by Necho, the Egyptian king, who on desisting from the canal which he had begun between the Nile and the Arabian

Gulf, sent to sea a number of ships manned by Phoenicians, with orders to make for the Pillars of Hercules (Straits of Gibraltar), and return to Egypt through them, and by the Mediterranean.

"The Phoenicians took their departure from Egypt by way of the Erythraean (Red) Sea, and so sailed into the southern (Indian) ocean. When autumn came, they went ashore, wherever they might happen to be and having sown a tract of land with corn, waited until the grain was fit to cut. Having reaped it, they again set sail; and thus it came to pass that two whole years went by, and it was not till the third year that they doubled the Pillars of Hercules, and made good their voyage home.

"On their return, they declared—I for my part do not believe them, but perhaps others may—that in sailing round Libya they had the sun upon their right hand. In this way was the extent of Libya first discovered."

Another account of a voyage tells of Hanno of Carthage sailing down the northwest coast of Africa about 500 B.C. to establish new Punic cities and to explore. According to some historians he got as far as Cameroun.

Wind Ships

But these accounts say nothing about the return voyage when the ships would have been obliged to sail north along the west coast of Africa in order to reach the Mediterranean. Many historians believe that these ancient vessels with their single square sail and oar rudder, could not have managed to force their way through the adverse winds blowing all the year round between Cape Verde, north of Dakar, Senegal, and Cape Juby, just above Tarfaya in southern Morocco.

Indeed, this kind of craft could only be propelled by the wind if it came from astern. This was because of the simple kind of rigging used and the sail's position. To travel into the wind, providing it was not too strong and the voyage not too long, the ship had to rely on its bank of oars.

Around 1500 B.C. however, naval technology was revolutionized when ship builders discovered a better balance between the sail and the lateral plane of the

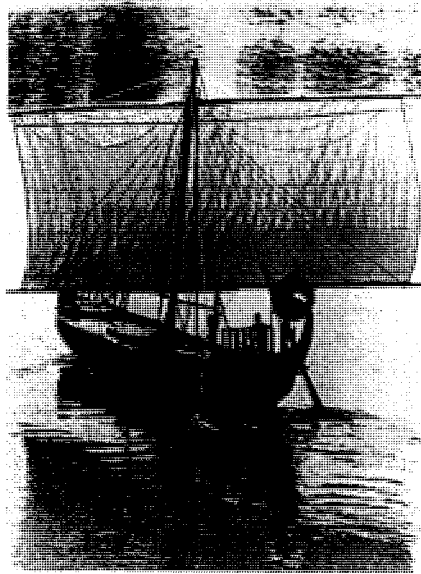

The **Pount**, a full size reproduction of an ancient Egyptian boat, shown here in a scale model, sets off in 1977 to reproduce the trip around Africa made under Pharaoh Necho II and recorded by Herodotus.

vessel, comprising the underwater part of the hull and the rudder. This made it possible to use the sail regardless of the direction of the wind. Nevertheless, these more sophisticated ships continued to be equipped with oars for use in calms and for maneuvering in ports and estuaries.

An Egyptian bas-relief from about 1500 B.C. depicts ships of this kind bound for the land of Punt at the mouth of the Red Sea. The carving comes from the funerary temple of Queen Hatshepsut at Dayr al-Bahri, near Karnak, and shows all the features of a ship able to sail the high seas.

So accurate is the carving in detail and proportions that, on the basis of it, Gil-Artagnan and de Tauriac were able to make and successfully test a scale model of the ship. The vessel is depicted so clearly that de Tauriac has succeeded in rediscovering the ancient Egyptian art

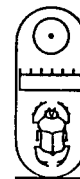

of binding the keel with rope, maintaining the curved hull taut as a drawn bow, and thus compensating the lack of a rigid keel.

De Tauriac and Gil-Artagnan now plan to build a full size, twenty-four-meter (eighty-foot) replica of an ancient Egyptian vessel. They hope to set off in the summer of 1977, following the same route around Africa as Necho's sailors. The ship will be named the *Pount* (French spelling) after the destination of Hatshepsut's expedition.

There will be many ports of call on the 30,000-kilometer (19,000-mile) trip—expected to take two to three years. On board will be a compliment of eight or ten people including a physician, a chemist, an archeologist, and a linguist. During the voyage a documentary film will be made and afterwards the ship's log will be published. The organizers also hope to carry out scientific and

scholarly research on behalf of a number of institutions.

To support the venture, a Punt Association, whose members are drawn from universities, the French navy, etc., has been set up under the presidency of Egyptologists Jean Yoyotte, Director of Studies at the School for Applied Advanced Studies (Ecole Pratique des Hautes Etudes), Paris.

Like Gil-Artagnon and de Tauriac, the association members are betting that the sailors of ancient Egypt could indeed have made the long haul round the continent and past the West African trade winds, and that the new Punt expedition will prove it.

—Unesco Features

For those interested in helping the expedition, the address is Association "Pount" pour l'étude des navigations égyptiennes, 4 avenue Hoche, 75008 Paris.



Medifocus

Medifocus is a special humanitarian monthly membership activity with which each Rosicrucian is acquainted. The significance of the personalities shown each month is explained to Rosicrucians as is the wording accompanying them. (The Rosicrucian Order, AMORC, is *not* a political organization. The basic purpose of *Medifocus* is a humanitarian effort directed toward world peace.)

July: Mr. Suharto, President, Indonesia, is the personality for the month of July.

The code word is TOLL.

The following advance date is given for the benefit of those members living outside the United States.



FERDINAND MARCOS

September:

Ferdinand Marcos, President, Philippines, will be the personality for September.

The code word will be SCALE.



SUHARTO

The
Rosicrucian
Digest
June
1976

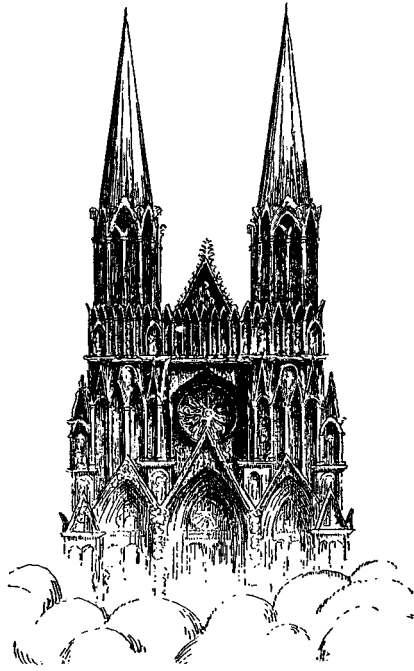

The Celestial Sanctum

NECESSITY

by Chris. R. Warnken, F. R. C.

MENTION OF THE WORD necessity usually brings to mind thoughts of compulsion, duty, unwilling action, or perhaps inadequacy. Seldom is necessity thought of as a cosmic blessing. But it is! Much of the evolution and progress of mankind has been brought about through necessity. It is an observed fact that when man is relatively content and happy, or lives in ignorance, he is reluctant to change his status quo. It is change that makes progress and evolution possible.

It has been recorded that throughout history most great governments or empires have failed to grow and advance for more than two hundred years. In that period of time they have become

smug and self-satisfied or overconfident. They lose their ardor for idealism, patriotism, and enthusiasm. Dedication to unity is lost; no longer a nation, they split up into a collection of antagonistic factions fighting among themselves. Perhaps this is worthy of a personal study of history for verification or rejection.

Most human endeavor, including nations, is founded upon necessity of some sort. In *The Republic*, Plato reminds us, "And yet the true creator is necessity, which is the mother of our invention." The wonder of it is that apparently all things are possible—if the need is great enough! Our many technological marvels that today's children take for granted were seldom dreamed-of miracles to those of generations in the past. The same natural laws were available then as are available to us, but the feeling of necessity was missing. It is a tragic observation that the crises of wars have usually been responsible for the necessity that inspired great scientific and other advances in the progress of mankind.

We can always learn from nature. It is said that nature adapts. Leonardo da Vinci captured this thought in his famous *Notebooks*. He wrote: "Necessity is the mistress and guide of nature. Necessity is the theme and artificer of nature, the bridle and eternal law." Nature proves that all things are possible. In the natural sciences one may encounter vast numbers of natural adaptations brought about through necessity. We are reminded of certain fish that have always lived in the waters of a subterranean cave and have never known light. They are physically blind, but they "see" by other means in order to live their normal and natural lives.

It has been said that certain bees are aerodynamically incapable of flying, but they must fly to fulfill their inherent purpose—and so they do! The blossoms of certain tiny orchids appear remarkably like a wasp, thus attracting the male wasp upon which it depends for pollination. The Caligo butterfly has spots under its wings that appear exactly like the eyes of an owl. This defense is used to surprise and frighten away its predators. To compensate for the lack of nitrogen in its native swampy soil, the Venus's-flytrap plant long ago developed leaves which trap nitrogen-rich insects which are then

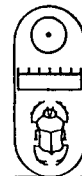

slowly consumed. Such adaptations born of necessity are fascinating and inspirational to man.

Man naturally resists change and therefore retards his potential improvement. He invents many excuses for refusing to move forward. He may insist that he does not possess the required health or strength, the educational or mental capacity, or the funds to do something different or better. In his present state of mind he may be correct. He really means that the proposed changes do not motivate him sufficiently and would be inconvenient for him. But if he becomes motivated by necessity, he can do anything! "The force of necessity is irresistible" wrote Aeschylus. Publicus Syrus wrote: "Necessity knows no law except to conquer." Both confirmed that in necessity all things are possible.

It is reported that psychologically paralyzed persons have risen and walked—or run—when confronted with a disastrous fire. A young boy lifted the front end of an automobile to free his father who was trapped under the vehicle when repairing it. The boy could not possibly lift the equivalent weight as a test. Thousands of loving parents have risked or sacrificed their own lives when confronted with the threatened death of their own child. They did not think of any risk to or sacrifice of themselves, only the necessity to save and protect their offspring.

Unfortunately, governed people are sometimes imposed upon with a false claim of necessity. William Pitt stated: "Necessity is the plea for every infringement of human freedom. It is the argument of tyrants; it is the creed of slaves." This is true, for the story is repeated throughout history. The majority of mankind prefers not to accept and learn the lessons of history. History reveals that the claims of necessity by tyrants were indeed false. Such claims were used as an easy excuse before apathetic and lethargic people who had surrendered their honor and human dignity—no longer being motivated by the absolute necessity of human freedom. Many of us only value and appreciate human freedom after we have lost it.

If we will agree to learn a lesson from nature, we can accept the principle that

there exists a potential solution to any and all problems. It may require a complete change in our thinking and our "normal" way of life, but the problems can be solved! The starving man will not simply lie down and die. He will try eating heretofore inedibles; he will seek elsewhere; he will beg; he will steal. He will die only after every other attempt to obtain food has failed. He has been motivated by necessity. No man will calmly give up his life or anything that is precious to him without struggle or effort, for necessity demands it. The reason man has survived the ravages of all kinds of natural disasters for ages is necessity. He is stronger and better for his struggle.

Man has inhabited this earth for only minutes in the long historic "day" of this planet. His progress during those minutes has been ever accelerative. With his unique self-realization man has glimpsed his potential of perfection and he seeks to hasten its attainment. His explosive rate of advancement during the twentieth century alone would astound his ancestors of the nineteenth and eighteenth centuries. He is now turning his attention more to the realms of the mind and soul. Thus, his future advances in the twenty-first century are certain to depreciate ours into the commonplace. Modern man has ascended the mountain and has seen the "promised land." He must attain it, for he has been motivated by necessity. △

The Celestial Sanctum

is a cosmic meeting place for advanced and spiritually developed members of the Rosicrucian Order. It is the focal point of cosmic radiations of health, peace, happiness, and inner awakening. During every day, periods for special attunements are designated when cosmic benefits of a specific nature may be received. Nonmembers as well as Rosicrucian students may participate in the Celestial Sanctum Contacts. Liber 777, a booklet describing the Celestial Sanctum and its several periods, will be sent to nonmembers requesting it. Address Scribe S.P.C., Rosicrucian Park, San Jose, California 95191 stating that you are not a member of the Order and enclosing twenty-five cents to cover mailing.

The Universal Conversation



*The conversation we
call music*

Ken M. Sillcock, B. Agr. Sc., F.R.C.

UNTIL MY RETIREMENT, although I enjoyed recorded music, I had little time to be still and give it my full attention. Music had become a background at mealtimes or an accompaniment to writing or doing chores about the house.

Now that I am listening to music at more leisure, I have found that each hearing of a record reveals more of the inner parts which support what would otherwise be a thin melody. Having played band instruments, I was well aware that these parts existed, but only lately have I really heard them as conversations between instruments, or, in piano and organ music, between different voices of the one instrument. This is true whether the music be classical, light comedy, or some of the more tuneful of modern works.

The measured remarks of the bass never fail to complement the comments of the higher second- and third-part instruments. Though the bass surreptitiously changes the nature of its rather dogmatic pronouncements, the other instruments always suit their comments to these changes.

A single instrument tells a short, simple story, which the others take up in a flurry of gossip. In this way, the tale is given new twists and differing emphases. There are also conversations between two instruments or groups, one reiterating its point of view and the other either endorsing it or disputing the statement and proposing an amendment.

But whatever form the conversations take, each is a new and different creation, although they are all built from the same material provided by the thirteen frequencies which make up an octave.

Is this also the very nature of our universe? If it was created by a Word, then surely it would be enlarged and diversified by an interaction of words; that is, by a series of conversations. If this is so, then science, philosophy and religion are all attempts on our part to unravel and understand the "conversations" which give the universe substance. Perhaps herein lies the unity between these diverse branches of human thought.

Conversations also weave much of the social fabric of our lives. Consider the people who shrink from any act of physical barbarity yet will not hesitate to be rude and hurtful in their speech. What deep divisions are caused by arguments between political parties which, when in power, have to do much the same thing in order to maintain effective government! And how often do we fail, by default, to add to the comfort and the niceties which can be created by the simple use of just a few words.

It has been said that actions speak louder than words, and we have been

(continued on page 30)

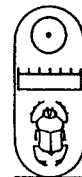

The Spoofer

by Mary Jackson



*Seeing the humorous
side of life*

AS I MOVED toward my mature years, a time when most people are naturally taking life a bit more seriously, I began to move in the opposite direction—toward frivolity. What caused this change I have no way of knowing, unless it was the insidious feeling that perhaps I had missed something, a feeling that life should be fun.

Although I considered myself quite sane and well balanced, I longed to be normal. The seriousness of life to which I had attached myself had weighted me down, all out of proportion, until I developed the unique ability of being able to detect tragedy in the strangest places. I'm quite certain that I was the only person who could see the tragic side of a circus, a day of sunshine, or holding a winning lottery ticket.

I have always had a healthy respect for life's tragedies. Grimly wading through the business of living made it impossible for me to see that one of the peculiarities of life was that its tragedies are often comical. Born of this peculiarity was satire. Needless to say, I considered satires not only sacrilegious, but I thought laughter desecrated life in general. I made a special point of shunning any unnecessary amusement and avoided comedy in any form. But people love to tell funny stories. They had the annoying habit of approaching me and saying,

"I know you don't like to laugh, but . . ." and proceeding to tell their tale.

My peculiar slant on life led me to concoct an unnatural link between laughter and noise. I noted that in their quest for joviality, people noisily scurried through life chattering, laughing, playing their stereos at top volume, allowing their dogs to bark freely, all quite oblivious to noise pollution.

I failed to understand how most people found it inconceivable that one might genuinely prefer silence to this disagreeable clamor. Schopenhauer, one of the greatest thinkers of his time, was perhaps one of the few whose leanings were akin to mine. He once wrote: "The super-abundant display of vitality, which takes the form of knocking, hammering, and tumbling things about has proven a daily torment to me all my life long. There are people, it is true—nay, a great many people—who smile at such things, because they are not sensitive to noise. . . . The reason of it is that the tissue of their brains is of very rough and course quality. On the other hand, noise is a torture to intellectual people."

I, too, entertained the illusion that my quiet austerity was superior, akin to lofty intellectualism, and I looked disdainfully at those who found life amusing.

Speaking of noise, the musical comedy comes to mind. It seemed that nothing was sacred to the makers of these musicals, and obviously there was no theme which could not become grist for their musical mill. These culprits, for example, had taken *Raisin in the Sun*, and had set it to music.

*The
Rosicrucian
Digest
June
1976*

There was a time, of course, when I could have aired these views freely and would merely be labeled eccentric; now, in the fashionable era of psychoanalysis, I'm usually labeled neurotic.

I knew that I had to mend my ways if life were to be any fun. I could only blame myself for placing this heavy burden on my shoulders, condemning myself to go through life untouched by gaiety. Would it be possible for one who had led a somber life to turn to a more trifling existence? I felt I owed it to myself to at least try.

I decided to start small. First I'd learn to grin, then to smile and finally to work it up to a belly laugh. Every morning I'd go to the bathroom mirror and begin my exercises. Everybody knows how painful it is to move muscles that have remained rigid for so long. As my face was subjected to this new way of life, the pain was exceeded only by my determination. Most of the time it didn't even resemble a smile but rather a grimace. Did you ever have occasion to watch the face of an insincere person who is smiling at you, while knowing full well they despise you?

After several weeks my face muscles loosened up and I went about testing its value. I discovered that one who smiles excessively can easily be labeled "*a bit daft*" but I didn't let it distract me—I kept right on smiling at every opportunity.

Pushing on, I threw myself into the throes of Greek comedies, waded through satires, engaged in the theater of the absurd, and exposed myself to the merriment of day-to-day living.

Since I had always been deeply committed to the correction of abuses and inconsistencies of our age, I made it a special point to focus on a satirist approach to these conditions. The ability to capture the absurdities of the human condition was as difficult for me as anything I had ever attempted. I tried to swallow it whole without barely chewing and, like some ironic magic, I began to get the hang of it. I finally reached the point where I could even stretch my imagination enough to visualize *Les Miserables* done as a musical comedy with Jean Valjean skipping happily down the stage carrying a loaf of bread under his arm.

After a while I began to see humor in the strangest things. I listened to a news report recently which would have ordinarily infuriated me. First the public was informed that statistics showed there were more murders committed in the months of July and December, and then an attempt was made to explain why this was so. A criminal analyst claimed that, "The heat and humidity of July probably caused people to become irritated and therefore to commit more murders. On the other hand," he further explained, "December is a cold month and thus a correlation could not be made." In conclusion the chap admitted that, "They really didn't know why people committed more murders in July and December." Tears of laughter rolled down my face. Good grief, if they didn't know, why had they bothered to bring up the whole thing in the first place?

At one point I was afraid that I might be falling into a pit of extreme, leaning toward the opposite end of the pole from which I had come. I suspected this when a friend who was quite upset confided that she "*didn't feel fulfilled as a woman*" and I burst out laughing.

As a result of this metamorphosis, my reputation was taking on a noticeable change. Unlike the good Doctor Jekyll, who had had the misfortune of seeing the darker side of himself, I had the chance to see the lighter side of myself. Friends began to accuse me of never taking anything seriously anymore, and once I was even referred to as "The Spoofer." There could be no greater compliment!

I knew I had reached my goal when I could finally laugh at myself. My idealized image, that could never be distracted by comic relief, had suddenly taken on a human quality—a smile. My midlife had taken a turn that I had never expected. My face no longer showed signs of strained tragedy and my ability to laugh, especially at myself, became the midpoint of enjoyment.

It was a point where the burden of life didn't finally rest on me, and now, when I work seriously at cultivating a better way of life, I'm in a better position to be more effective and successful.

There's going to be a showing tonight of *Les Miserables* on the Late Late Show—I think I'll watch, just for fun! △

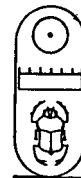

Is God An Energy?

by Ralph M. Lewis, F. R. C.

MAN'S CONCEPTION of God is very limited. There are many definitions of God such as Universal Mind, Absolute Being, Cosmic Intelligence, Light, Love, Life. Why is there no popular conception that God is an Infinite Energy?

If we think about it a moment, free from an emotional allegiance, we must conclude that it is extremely presumptuous for man to think that his *finite intelligence* is capable of embracing the absolute nature of the infinite. Whatever the qualities of such a cause, paramount would also be the fact that such would exceed the border of any sense qualities from which man derives his ideas. Simply, if anything can be defined as *unknowable* in its *absolute* state, it would most certainly be the nature of such a thing as a First Cause regardless of whatever other term man might assign to it.

Yet the mystic speaks of apprehending, that is, contacting, and of experiencing the Divine, the Cosmic or God by any of various delineations. Are we then denying that the mystic has had such an experience? The mystic has transcended

in his mystical experience the limitations of his peripheral or receptor sense qualities. He has become aware of the extent of a state or condition that transcends any objective experience. It causes him to enter into an ecstasy, an exalted feeling of pleasure.

However, following the mystic's subjectivity there is then his endeavor to convert the elements of his experience into objective terms. He transforms the experience into words, forms, and qualities which he can understand. More succinctly, he creates a mental *word image* of his experience which is related to his particular intellect, education, and general association.

For example, the Buddhist having such an experience may call it *Nirvana*; the Muslim might say that *Allah* was revealed to him; the Jew, *Jehovah*; the Hindu, perhaps *Brahma*; the Parsi, *Ahura Mazda*. Unfortunately, the religious zealot will generally insist that the particular experience which he has had is the absolute nature of the First Cause, and furthermore—exactly as he objectively interprets it. He will be apt to be prejudiced against any divergent notion.

Initial Cause

We can therefore say that man creates his own image of the omnipotent and omniscient cause. Man creates God not in essence but in the qualities which his mind attributes to Him, the image by which he conceives this essence. As for the First or Initial Cause, which is thought to be ubiquitous, considering it an energy is just as plausible as any other concept. *Thought is energy*. Therefore, those who believe in a teleological cause—that is, a mind cause—would certainly likewise be admitting that thought is an energy.

Even the orthodox religious student will recall the doctrine of the Logos in John, Chapter 1, Verse 1 of the New Testament which states, "In the beginning was the Word, and the Word was with God, and the Word was God." This definitely implies thought being formed into the *energy* of the spoken word. Centuries before the compiling of the New Testament, the Egyptian priests said the God Ptah, who was a patron deity of the artisans and who likewise sym-

*The
Rosicrucian
Digest
June
1976*

bolized cosmic thought, created the universe by the spoken Word. We are told that Ptah "pronounced the name of all things."

There are those who conceive the primary cause as being a universal consciousness, but then again in our human experience we accept consciousness as an attribute of life, and life in its vital force and function is likewise an *energy*. Furthermore, whatever man conceives this cosmic essence or substance to be, it is by the very fact of *being*—so far as human experience can conceive it—a parallel to energy.

A disembodied mind energy, as the creative force in the universe, is not generally accepted by the majority of the world populace. It is principally because of the human tendency of attributing to a supreme Initial Cause qualities similar to those of man's own being. For example, man is causative; that is, he is conscious of introducing changes or innovations in his own surroundings and his own actions. He equates this volitional causation with personal freedom and creativity. He is aware that such give him a superiority over most all other life forms. Consequently, he is thus inclined not to attribute any lesser power or quality to what he considers a transcendent superior being.

To say that the Cosmic—a universal creative cause—is an energy would only be offensive to those persons who prefer an anthropomorphic god; that is, one having humanlike form. However, these persons are then denying their god as being determinative or having will and purpose, for certainly will and purpose are related to mind, and mind in its manifestation is energy.

Modern science has given an equivalent to matter and energy at least to the extent that there is an interchange between them. Simply, behind all reality is a kind of electromagnetic spectrum; its range or limitations being unknown. Generally, scientists do not concede that such a phenomenon is God. But *if* that phenomenon is the basic cause of all that exists, then whatever man chooses to call it, it is the *Creator*. To state that such an idea is a sacrilege is actually to assume that man does know the exact nature of God.

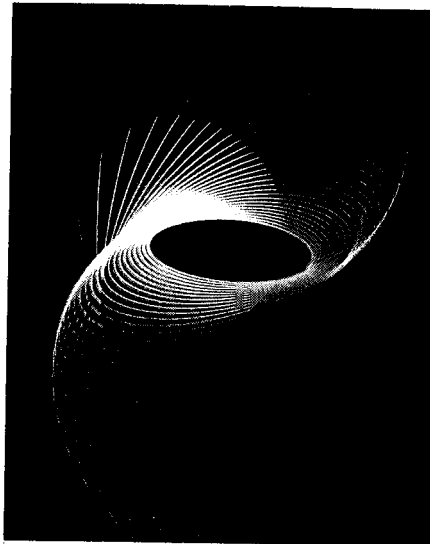

Jerry Chapman

This then brings up the question of the authoritative nature of the sacred religious works which are all quite specific in their definition of a God. The first outstanding fact to be observed from the reading of such literature is that these works are not in agreement on their concept of a primary or divine cause. Therefore, another point of view, such as that of a cosmic energy whose order or manifestation appears to be related to the energy which we know, has as much right as an abstract speculation as any of the other so-called sacred expositions.

In conclusion, let us realize that the sacred works derive their authority principally from the declaration that they are the result of divine revelations. Nevertheless, the word description of these revelations are the construct of the human mind that objectified them. We may ask which was right or wrong: Ptah, Akhnaton, Moses, Zoroaster, Buddha, Jehovah, Mohammed, and numerous other personages or concepts which were held to be equally sacrosanct to millions of people?

Nevertheless, it is to man's credit that he does recognize a supreme *something* which lies beyond himself and which engenders within him awe, humility, and a love for as well as a desire to understand it. △

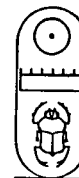

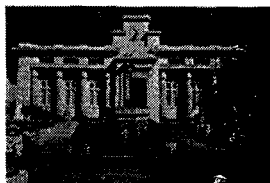

MINDQUEST

REPORTS FROM THE RESEARCH
DEPARTMENT OF ROSE-CROIX UNIVERSITY

Kirlian Photography A Tool for Psychic Research?

Alden Holloway,
Director of Research and
Development, AMORC
and

George F. Buletza, Jr., Ph.D., F.R.C.
Staff Consultant and member of
International Research Council,
AMORC

KIRLIAN PHOTOGRAPHY, also known as high-voltage or corona-discharge photography, is one of the most exciting and controversial subjects on today's technical scene. The potential for this process to help uncover new knowledge in the areas of psychology, parapsychology, medical diagnoses, and metaphysics has created many enthusiastic supporters. Others, including many scientists, are not at all convinced that the Kirlian process has any real value or application.

Aware of these extremes of opinion, a research project was established one year ago here at the Rosicrucian research labs in the attempt to learn all we could about the process and its possible applications. During the course of this research, different types of Kirlian-type apparatus were assembled and thousands of photographs taken. The following is a brief summary of some of our thoughts and observations.

Kirlian photography depends on the coupling of a high-voltage, high-frequency AC generator (Tesla Coil) to a subject. This is done in one of three ways. The simplest form (Fig. 1) places the object such as a leaf or coin, between parallel, capacitorlike, metal electrode plates, and separated by a small distance from a photographic plate. To photograph a human finger (Fig. 2) the subject's body is used as the second capacitor plate. A third arrangement uses a transparent electrode (Fig. 3).

The skin effect of the high-frequency power distribution causes the current to flow primarily on the skin surface rather than through the body. Most of the applied power is dissipated in the corona. The energy is expressed in a wide range of radiation, including components of the ultraviolet, visible, infrared, and electromagnetic (radio & TV) spectrum, as well as the electrical discharge.

*The
Rosicrucian
Digest
June
1976*

During the Kirlian process, a few electrons are first produced in the inter-electrode space; these are accelerated by the field and ionize air molecules, leading to an exponential growth in the number of electrons and positive ions. The electrons are attracted to the (+) anode and the ions more slowly to the (-) cathode. When the ions in the air reach a critical density, they strongly attract the electrons. Recombinations then occur and photons of light are generated.

The clusters of positive ions become brightly luminous and travel at high speeds. Both positive and negative streamers move between the electrodes, and discrete balls of light move in various directions. The normal color of the streamers is a bright blue (see cover photograph) since the radiation from excited nitrogen molecules predominates. This electrical process produces enough light to expose the film and results in a photograph of the type under discussion.

Now that we have a photograph of a fingertip, for example, exactly what does it mean? Many early experimenters thought that the corona surrounding the object photographed was the actual aura, or bioelectric "field" of the object. This idea was reinforced by the fact that the aura or corona often changes in intensity, size, and configuration in successive photographs when a subject alters his thinking or concentration. The famous "phantom leaf" experiment has also contributed heavily to this theory.

Bioplasma

In this experiment, a leaf is photographed, cut in half and rephotographed. The resultant image often shows a faint outline where the cut off portion of the leaf had been. In fact, some Soviet scientists have used this experiment to suggest that not only are we viewing the object's aura, but that this aura is actually a fifth state of energy termed "bioplasma." This bioplasma is supposedly a complete informational energy network associated with all organisms and is always complete and intact—even when part of the physical structure is severed.

The great problem associated with Kirlian photography is *interpretation* of the aura or corona. We know, as Rosicrucians, that everyone *does* have an aura or electromagnetic field surrounding his

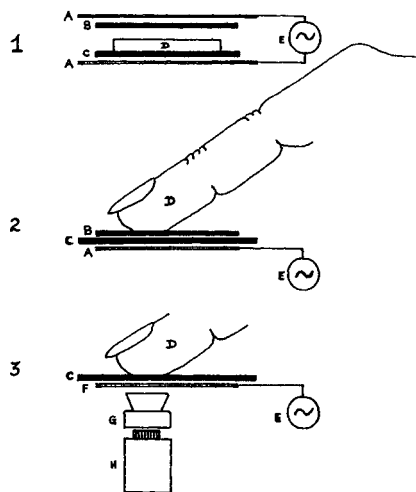

Three varying techniques for making Kirlian photographs. The letters refer to: A) Metal electrode plate, B) film with emulsion side to object, C) dielectric sheet, D) finger and object, E) Tesla coil, high frequency AC pulse generator, F) transparent electrode, G) light intensifier, and H) motion picture camera.

body. We can measure this field with sensitive instruments which indicate an output for the average person of approximately 1/1000 of a volt. What happens to this normal energy output, however, when it is subjected to the 30,000 to 100,000 volts discharged in the Kirlian process? Either the high-voltage discharge *follows* the contours of the existing normal aura, or it superimposes itself around the object being photographed so that we have only a photograph of an electrical discharge.

Our research to date has produced many interesting, though inconclusive phenomena and effects. Kirlian photographs of a subject's fingertip before and after vowel sound intonation, for example, have produced greatly differing images. Certain vowel sounds produce a brighter, larger aura, and other vowel sounds seem to diminish the aura. Heal-

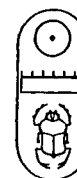

ing experiments produce great changes in auras. A subject's emotional state will seemingly change not only the size of the aura but the color as well. Many of these experiments have a high degree of repeatability.

Before variations in Kirlian photographs can be convincingly attributed to emotional or psychic experiences, however, the variables involved in the technique must be controlled. Among the basic parameters which can effect the Kirlian image are the following demonstrated in our laboratory: (1) voltage and line fluctuation; (2) pulse width, pulse rate, and frequency of signal inside pulse; (3) exposure time; (4) type of film used; (5) capacitance of subject; (6) pressure of subject against film and electrostatic plate; (7) angle of approach of subject's fingers to film and plate; (8) flatness of film against electrostatic plate; (9) moisture and dirt on either the film, plate, or subject's fingers. Other variables more difficult to control include: (10) gases in the atmosphere; (11) barometric pressure; and (12) atmospheric temperature.

This diverse list of variables is not necessarily complete. Insofar as signi-

ficant variables are not controlled, conclusions and generalization about experimental findings are not possible. This is particularly true regarding interpretations of mental state or healing energies, since evidence in the photographs may have resulted from totally unrelated and unknown phenomena.

At the present time our Kirlian research is centered around attempts to establish effective controls for as many of the parameters mentioned as possible. We also feel that the simultaneous measurement of other physiological data, such as body temperature, brain wave activity, respiration, galvanic skin response, heartbeat, etc., along with Kirlian photographs, may open new doors to knowledge. Experiments along these avenues are now underway and will be reported in a future *Mindquest* article.

If the current worldwide interest and attention focused on Kirlian photography do result in new techniques of control and interpretation then the possibility certainly exists that a new scientific and diagnostic technology may develop. Should this occur, the potential benefits to students of metaphysics and mankind in general will be enormous. Δ

Cover The brilliant blue and white corona surrounding these fingertips was created in the Rose-Croix University Parapsychology Laboratory by a process of high-voltage photography during a vowel intonation experiment. Coronal image intensities are altered by various Rosicrucian exercises. For further information, see this month's *Mindquest* feature on page 22.

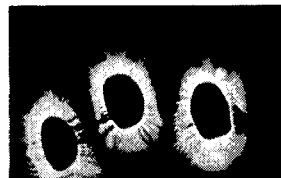

▽ △ ▽

**The
Rosicrucian
Digest
June
1976**

CONSTITUTIONAL GUARANTEES

The Rosicrucian Order, AMORC, operates under constitutional rule. This assures each member certain rights and privileges in connection with his membership. We feel that every member should be aware of these rules as set forth in convenient booklet form. The twenty-seventh edition of the *Constitution and Statutes of the Grand Lodge of AMORC* is available for 95 cents*. Order from the Rosicrucian Supply Bureau, San Jose, California 95191, U.S.A.

California residents, please
add 6% sales tax

*Foreign Currency Equivalents
£.50 A\$.75 NZ\$.95
¥.65 ₣1.20 R.80

The Dangers Of Bigness

by Walter J. Albersheim, F.R.C.

ALL TYPES of living beings seem to be allotted a normal life span and a normal size. An unusually long life, though universally hoped for, is often more burdensome than desirable, and it seems that even in the prime of life,

abnormal size has its drawbacks and dangers. The ancient Greeks had a superstitious fear of excess; they believed that any excess invited envy and the vengeance of the gods. The Roman poet Horace wrote that "storms topple the tallest trees first." Even now there is a common saying: "The bigger they come, the harder they fall."

The size limitations of living creatures have physiological reasons: Body tissues of each species are evolutionally adapted to a certain average or mean. If this is greatly exceeded, air and fluids cannot circulate efficiently, internal communications are strained, and the weight and leverage of the limbs increase faster than tissue strength. Nature allows some leeway, but gross abnormalities are considered by some companies as poor insurance risks.

Man-made organizations, too, seem to be subject to limitations inherent in their type. Nations and religious bodies may grow to a very large size and survive through many centuries if sustained by strong racial or spiritual bonds. But even nations and organized religions tend to become so rigidly dogmatic with age that they may require rebirth or renewal through revolution or reformation. But on the whole, industrial and private commercial companies have a narrower and more evident limit of growth.

In favorable periods, such as prevailed on the North American continent and in some of the South American countries as well, many business ventures mushroomed from small beginnings to giant size within one person's lifetime.

(continued overleaf)

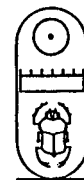
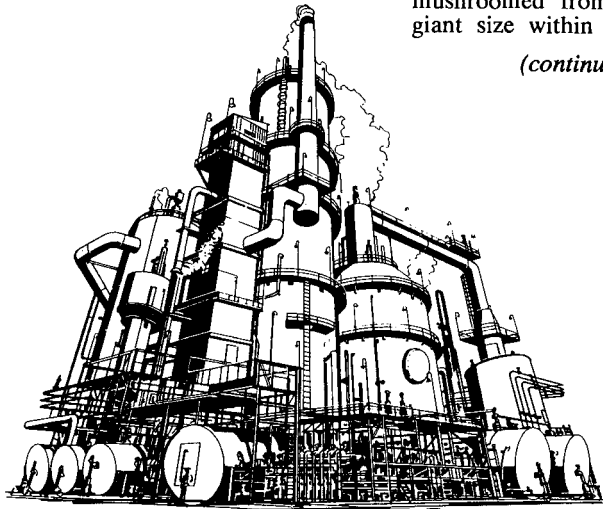

Some of these industries have successfully achieved the transition from one-man empires to well-run collective organizations and have thrived for a century or more. But for the great majority, there applies an old adage: "From shirt sleeves to shirt sleeves in three generations." Often the entire cycle is completed in even shorter time. It looks as if a "law" of corporate growth regulates the size and life span of each type of organization. Let us try to uncover this law by examples of the more common endangered business venture and the successful, thriving organization.

The founder of an average organization is usually an ambitious young person whose creative, imaginative gifts may not find sufficient outlet in the employ of mature organizations. Alone, or with the help of like-minded friends, the dynamic organizer undertakes a new business, usually based on a new invention or a new service. The product may be the proverbial "better mouse-trap," a new soft drink product, for example, or improved appliances such as a better sewing machine or an electronic oven. If the product succeeds, the initial rate of company growth may be spectacular. This requires an increase in personnel and in monetary expenditure.

For a while, perhaps, the young company will finance itself by utilizing its own profits for expansion. Company employees are soon absorbed by an "organic" type of growth; in other words, erstwhile mechanics become foremen or heads of production while bookkeepers and salespeople often become managers of finance or marketing. The organization remains, as it were, one happy family unit in which the boss knows all the original co-workers and their spouses by their first names.

Seldom can any company remain static; in order to succeed, it must grow. But this natural growth rate often tends to slow down, instead, and a time may come when growth-for-growth's sake quite subtly becomes more important than product quality, service, and human relations. Such inordinate growth requires seeking new capital from the money market. The money lenders gradually gain control of company policy and new department heads appear, hired according

to their interlocking interest with those who control the company finances, thus muting the voices of the old associates.

Some efficiency experts and personnel directors in these large impersonal corporations seem to be more concerned with formalities than with the individual employee's true worth. Because of the sheer quantity of personnel, these experts can only measure an employee's value by "correctness" or by the immediately apparent figures on the timecard along with the quantity of merchandise or paper work produced. Thus the really productive, potentially inventive types, who work for the future and are the real nerve centers of the most progressive, successful companies, are systematically eliminated.

Unfortunately this sort of thing can and does happen to the administration of churches, universities, fraternal organizations, and governments, as well as big business the world over. The resulting loss of morale and of creativity creates a degenerating condition in which the life blood of the organization circulates less freely than before; the lines of communication become clogged; and the corporate body suffers from hardening of the arteries with the attendant dangers of business paralysis and ultimate failure.

Service

In contrast to this gloomy outlook for forced growth, however, some large, mature organizations continue to flourish as well as experience phenomenal growth. What lies behind this success? Certainly such large corporations are not immune to the evils of red tape, labor disputes, production problems, and public relations.

One of the principal reasons seems to be that a successful organization does not stop placing emphasis upon *service*. It does not forget that its true function and purpose is only justified as long as it provides good and reliable service within an ethical framework which is extended to client and employee alike.

The standard of service is enhanced by progressive improvements based upon continued inventiveness. Therefore, creative minds are rarely overlooked in this sort of group. Ways and means are

found to discover an individual's worth. Those forward-looking employees are then encouraged and rewarded, and given a free hand to speculate, research, and develop new ideas which will lead eventually to a new product for the market. Naturally the results in morale and in hard work are spectacular. Members of the research staff not only can be proud to serve a successful and useful organization, but they can also feel that their contributions are known to top management. Often these accomplishments become published in prestigious, widely read periodicals. This encouraging environment attracts talented people and creates a sense of loyalty unheard of in most large organizations.

Our comparison between endangered and thriving organizations boils down to a prescription for health in spite of bigness that consists of just two words: *service* and *morale*. These two requirements are interlinked because a company cannot give good and dependable service

without high employee morale. The policies creating and maintaining such a positive state are both economic and spiritual. They are as follows: (1) Fair pay according to merit; (2) An interest in the company's welfare by profit-sharing or stock ownership; (3) Work security by trust in the company's sense of fairness and ability; (4) Old age security through a pension plan which is never violated by dismissal shortly before pension age; and (5) Pride in one's work, nourished by recognition, rewards, and promotion.

All of these policies can only be realized if there is a natural flow of truthful communication between suppliers, customers, employees, and management. The list seems rather lengthy, but taken altogether it amounts to nothing more or less than the Golden Rule: Deal fairly with one another; treat others as you would like to be treated. No organization that is pervaded by this ethical attitude need fear the dangers of bigness. △

Perception provides through experience the fundamental substance of thought; reason and imagination compound them into an infinity of ideas.

—Validivar

ATTENTION, HIERARCHY MEMBERS

Those who have attained to the Hierarchy and understand the purpose and importance of these special Contact Periods are invited to participate in and report on the following occasions.

First, *mark the dates* given below on your calendar. Arrange in advance for a few uninterrupted minutes at the given hour. While benefiting yourself, you may also aid the Hierarchy. In reporting to the Emperor, please indicate your key number and the *last monograph*, as well as your degree. The Emperor appreciates your thoughtfulness in not including other subject matter as a part of your Hierarchy report.

Thursday, August 19, 1976
8:00 p.m. (your time)

Thursday, November 18, 1976
8:00 p.m. (your time)

It is requested that those members of the Hierarchy who desire to participate in these periods prepare a little card showing these dates—to be placed in their wallets or some other convenient location where it will be a continual reminder of the next Hierarchy Contact Period. Such, of course, should be changed with each announcement of future dates.

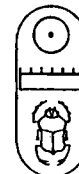

Up and Down Life's Ladder

by
Emmanuel Amariochi Okoro, F.R.C.

THE ACTS of falling and rising in life situations are looked upon as opposites. The former is looked upon as the negative aspect and the latter the positive. Everyone would like to rise to the heights at all times—be it to the heights of fame, affluence, or popularity. For surely no one would pray to have a fall in any venture, no matter what it may be.

But occasionally the individual, as well as mankind as a whole, seems to be condemned to descend from the heights. Why? After having fallen by degrees to find himself in the depths, man wonders how it all began. After making deliberate efforts, he feels that he should be advancing up the ladder of life, but sometimes situations still continue to move him on the way down.

Many an individual under such circumstances tends to give up trying to help himself and seeks to place the blame for his misfortune elsewhere. We have

all heard those who, being overcome with the burdens of life, exclaim: "Oh God, where are you?" In such a dark and cloudy life some lose faith in their god's powers to help them overcome this negative, unhappy state of affairs.

According to the individual concerned, there are variations and degrees to the occasional fall from the heights. For instance, let us consider the case of a particular doctor who, being progressive in his practice, was also very much admired by the populace because he was so considerate of others. This good man practiced the virtues of sympathetic, loving kindness, devotion to duty, and he placed the life of his patients before money and his own pleasure.

In time this doctor began to deviate from those high principles for which he was noted and respected, and his activities degenerated into avarice, wickedness, and neglect of duty. In his arrogance, he had forgotten to practice the virtues that had brought him his upstanding position in the community. But soon this unethical life began to precipitate a change in the doctor's life. His patients turned from him. His practice declined until he was overheard complaining: "Nothing seems to turn out right with me. The gods have forsaken me. I don't know what to do." Evidently this poor man had fallen down life's ladder.

Then there is the story of a notable trader who was quite trustworthy, polite, and friendly to his customers. Not being a profiteer, the attention, care, and concern he lavished upon his customers naturally drew many such clients from all parts of the country to his store. His business prospered and soon he found himself wealthy. But then pride set in. The trader's dealings with his customers became characterized by an "I-don't-care" attitude. His greed for more money grew, and this man began adulterating his goods.

Before long the customers discovered the fraudulent life the merchant was leading, and they no longer cared to trade at his store. Without customers the business began to fail. Unpaid bills began to accumulate. His wife who had married him when he was successful and rich now

*The
Rosicrucian
Digest
June
1976*

deserted him. Soon he could no longer afford to keep his children in school. The unhappy man wondered: "Why does God refuse to care for me?" No doubt the merchant had fallen from the heights.

There was once a philosopher who devoted himself to the study of life. His whole desire was the quest for knowledge—the search for truth. He found joy and pleasure in his branch of study. In his community this most exemplary gentleman became radiant with his thoughts on love, light, and life. But then something happened. Other pursuits gradually claimed all his attention, replacing his regular studies. The philosopher began to make excuses that there were not enough hours in the day and that there was not a conducive atmosphere in which to pursue his former studies. Life was no longer radiant with love and light.

The philosopher was unhappy. But there seemed to be nothing that he wanted to do in order to rectify his unhappy state of mind. Pride forced him to passively accept his negative condition, which only attracted other attitudes such as procrastination, indecision, and laziness. He failed to comply with and employ his favorite motto: "Whatsoever thou resolvest to do, do it quickly. Defer not till the evening what the morning may accomplish." Unfortunately this philosopher made no effort to leave the bottom of the ladder where he had fallen.

Opportunities

We should not respond to falling down life's ladder by passively accepting a condition under which we must be condemned and compelled to remain. Let man learn from the last words of Black Beauty to her colt: "My child, if it shall ever befall you to run for your dear life, run for it bravely, and when you dare run no more, face your foe bravely. But never, never lie down and quell. . . ." To quell is to give up. The truly negative aspect of falling is to fall and remain flat without the effort to rise again.

When we find that we have fallen from the heights, this act of falling should be tapped and exploited to our advantage. The experience of disaster in our lives



Portion of Salomon Trismosin's **Splendor Solis** (16th century). The painting contains alchemical symbology with the alchemical Tree of Life in the center.

should serve as a stepping stone to success—a strong foundation stone in which we can build a strong, permanent structure like the Biblical house built on a rock which no wind could demolish.

All men experience reverses; therefore we should neither be afraid nor ashamed of falling off from the good in our lives. The experience gained from just such a fall offers us the opportunity to reflect and to perceive further than our own limited view. Rather than fear or shame, man should feel pride in being able to pick himself up off the bottom rung of the ladder, reorienting himself toward the upward climb, utilizing—this time—the very rich experiences gained in the previous fall. The "sadder-but-wiser" man

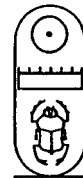

does not allow himself to be weighted down by a loss of faith or inertia. Man has made remarkable progress from the lessons of others who fell from their own heights only to rise again with discoveries and inventions born of their experiences.

The positive attitude is that we should never accept defeat. The act of falling can only have a negative aspect when we accept this adverse condition as final. Whenever we find ourselves in one of life's dark moments, let our thought be: "Do not triumph over me, O my enemy

(the condition of falling); for after I fall, I shall rise."

Man should humbly recognize and accept the ignorance of his past thoughts and actions, profit from the lessons learned in his adversities, and go forth toward new heights in achievement. But when we must learn unhappy karmic lessons on the ladder of life, let our thoughts be triumphant with the faith that "When I find myself in a dark cloud of life, I press God's lamp close to my bosom. Sooner or later its glories will pierce the gloom. I shall emerge." △

The Universal Conversation

(continued from page 17)

urged toward "deeds, not words." But, though sincere, kindly deeds mean more than insincere protestations, let us not underrate the power of words spoken sincerely. Looking back to the shattering events of 1939 to 1945, we discern two voices which created more of the situation than did the most courageous activity. One was the voice of the rabble-rouser, sincere but misguided, which persuaded a whole nation that its rightful destiny was to conquer the world. The other was the voice which could promise nothing but blood, toil, tears, and sweat, but which nevertheless made an unprepared nation believe, rightly, that it would never surrender. No amount of action could have influenced the course of history as profoundly as did the spoken words of these two men.

Conversation, of course, consists of more than just syllables uttered one after another. Subtle inflections, gestures, and even demeanor without words are all parts of the communication. On coming home from work I need no spoken word



to tell me whether there has been peace or strife there in the preceding half-hour.

In the conversation we call music, the essence is change; for what could be more boring than the same scrap of melody repeated over and over again without variation of any kind? Similarly, in human conversations and relationships there is always this process of change and development. Therefore, should we be too disturbed over even the most distasteful quarrel in which extreme things said by the participants would shock them in their calmer moments?

Even those who are rude to us are, at that very time, undergoing a change which will be for the better if only we have the fortitude to avoid repaying their rudeness with rudeness of our own. We do better to take our stand firmly but calmly, to use humor or a kindly remark, to make an apology if we have been at fault, to explain a misunderstanding, or, if these will not work, to ignore the person until his mood has altered. Always there is the new phrase, the new tempo—not far into the future.

In words and deeds let us then be good thinkers and, arising from this, good conversationalists in all the processes of our universe. △

**The
Rosicrucian
Digest
June
1976**

Dr. H. Spencer Lewis, F. R. C.

Cosmic Politics

IT IS GENERALLY understood that the Rosicrucian Order does not deal in political matters to the extent of advising its members to support any political party or candidate for any office. So far as political alliances are concerned, it remains absolutely neutral and the only thought that is given to these matters is to determine which of various candidates is best qualified from a universal point of view. Personal views regarding candidates and political principles may from time to time be expressed, but it has never been expected that members adopt such opinions as a matter of course or as incidental to their membership.

The mystic and the student of natural philosophy may be inclined to believe that politics constitutes a field of activity and study entirely outside his realm; but he forgets that the Cosmic is greatly interested in politics: Without a political scheme of some kind, the Cosmic could not carry out its universal principles.

In the course of many years, I have noted with much satisfaction that in complicated situations the Cosmic intervenes and selects for a position the person best fitted to meet the crisis. In fact, in the intervention of the Cosmic, we have a distinct revelation of the political acumen and comprehension of things political here on earth.

The cyclic birth of an avatar in each nation, the periodical rise of a great leader to guide the thoughts of men, and the powerful influence of a savior in times of stress point to a supreme, divine, omnipotent comprehension of man's

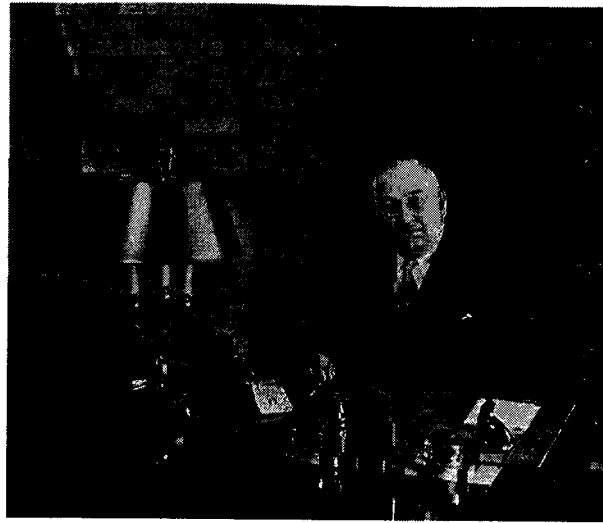

needs and a dependable intervention on the part of a God and the cosmic forces when we are in need of superior guidance.

This does not mean, however, that we should fail to study the situations that have arisen from worldly affairs. With the human error that is inevitable, we make mistakes from time to time, and these must be corrected. This lies in our own hands to a great extent.

Analyze the Situation

Inasmuch as man has taken unto himself the prerogative of creating laws for governing himself and his fellow beings and has also assumed a superior position in interpreting God's universal laws and applying them in a specific way, he has assumed a responsibility that he cannot cast aside or pass on to God and the Cosmic. For this reason if no other, each individual should give serious thought to the selection of candidates for such offices as control the administration of man-made laws and their interpretation.

Man can do his best in this regard by keeping in mind the political attitude which must be that of the Cosmic. Certainly, the Cosmic does not take into consideration the religious, racial, or color distinctions which man has magnified to such artificial importance. In the sight of God, all the children on earth are of one human family. Regardless of

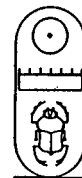

race, color, or religious faith, the peoples of the world have problems that are much alike. They can be solved only by a common understanding and application of sensible interpretations of fundamental principles.

We should, therefore, analyze each political situation from its international and universal point of view rather than from that which is distinctly local. A mayor of a small city is not simply an administrator of the interests within the confines of that city, but he becomes a member of a more or less universal hierarchy of worldly administrators.

His actions, decrees, rulings, decisions, interpretations, and evolving ideas cannot be separated from universal interests. At any hour of the day during his term of administration, he may become an important national figure or even an international influence. His influence upon the people within his own city can become of nationwide importance. A president of the United States is not only an administrator of the interests of the United States, but he is also a part of the international scheme of administration. We must consider his qualifications to meet the international problems that may arise along with the local ones.

Analyze the Individual

In analyzing the individual, we must not be guided by party ties and affiliations nor by promises made before election, no matter how sincere and honest they may be. We must consider the candidate's tendencies in situations not anticipated or expected at the present. We must judge him not by what he wants to do in the future, but by what he may be capable of doing under stress or in circumstances now unknown.

It is probably true that the average political candidate is eager to be a better administrator than his predecessor and to make his administration a monument to his integrity, goodness, honesty, and creative powers. But this desire, this honest intent, is not the most important thing to consider. We must analyze his character, his abilities, his methods of thinking, and his fundamental appreciation of cosmic and universal laws.

There are millions who vote blindly for one or another of the many candi-

dates, believing that all are good or all are bad and that any attempt to select one as better than the others is a waste of time. They consider that it makes little difference who is elected inasmuch as political influences, conniving, and underhanded scheming will control the candidate's actions regardless of his claims.

This is the wrong way to look at the matter and the wrong way to vote since it fosters the very situation that is so seriously criticized. There have been candidates in the past who have been elected to office on the basis of their promises, and they have sacrificed their future success and fame by remaining steadfast to the promises made, fulfilling their obligations regardless of all pressure from the outside and all temptations.

We can encourage men of fine character and fine mind to take an interest in political matters by showing in our voting that we are using discrimination and approaching the subject prayerfully, analytically, and cosmically. There is no power on earth of a mundane nature greater than that of public opinion. It is a complementary and secondary power to cosmic law.

If all human beings would unite in a demand for universal peace by thinking only of peace, brotherly love, and universal prosperity and happiness, not only would the thought of war be eliminated from the minds of those who make wars possible, but even the reflection of this power of opinion would affect the cosmic laws.

Universal peace would become an immediate and unchangeable condition. When public opinion in any locality or nation centers upon certain demands that are righteous, reasonable, and fair—especially of general good to all—political powers, parties, and leaders are set at naught and can accomplish nothing in the face of this decision on the part of man.

A man elected to office by the universal opinion of the majority, which believes and demands that he do the things that are right, is given from the Cosmic the power to fulfill the demands of the public. He is fearful of any variation from those demands. In such a case, the public must assume all responsibility for its judgment. This man is in a posi-

tion to exert powerful influence and be the master of his own fate in a political sense just as he is the master of his personal life. He must, therefore, assume the responsibility for his own acts.

It is right and proper that members of the AMORC, attempting to work in harmony with universal cosmic laws, should analyze political situations, select their candidates, and vote for those whom they honestly believe will conform to cosmic rules and give the public the best service possible. Part of our duty lies in attempting to make worldly conditions right in a

national or community sense as well as in a private, social sense. After all, we are our brother's keeper in a wide interpretation, and a nation's karma can become a part of our own.

Since thousands of readers of the *Rosicrucian Digest* have not read many of the earlier articles of Dr. H. Spencer Lewis, first Emperor of the present Rosicrucian cycle, each month one of his outstanding articles is reprinted so that his thoughts will continue to be represented within the pages of this publication.



THOUGHTS

"Look well to your thoughts for out of them emerge the great issues of life." Have you ever sat down at the end of the day and looked back on your thoughts for the day? Were you proud of them? As every thought has a good or an evil effect, what effect did your thoughts have for today?

"As a man thinketh in his heart, so is he." You alone are responsible for your thoughts. Your thoughts may vibrate to the ends of the universe but you are the closest to your thoughts and therefore will be the one to benefit—or suffer—the most. If you train your mind to think along the lines of honesty, uprightness, morality, temperance in all things, love of fellow-men, kindness and consideration to everyone, you are more likely to have these qualities externalized in a clean-cut personality and a healthy body. If, on the other hand, your mental storehouse is stacked with fears, doubts, animosities, greed, and things worse, it will act as poison to the body and mind and you will have these evils clearly stamped upon your features.

The power of thought was adeptly expressed many years ago but ever applicable to present-day human affairs: "There is nothing either good or bad, but thinking makes it so." Therefore, it is well for one to watch his thinking. As a group, so too will our thoughts affect our organization. If we think constructive thoughts of succeeding in our every undertaking, we can do much to aid the work of the Rosicrucian Order and thereby aid all mankind. Let us always send out thoughts of **love, kindness, and peace.**

—Dorothy Deiner, F. R. C.

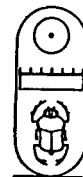

Thanks for The Compliment

(continued from page 7)

This aspect of sincerity is of course of paramount importance when bestowing a compliment, however small. To be really potent and effective in its context, a compliment must be pure—unmixed with flattery. “The more we love our friends,” says Molière, “the less we flatter them.” This may need practice in looking for the praiseworthy in the other person, but no good is done to either by blatant flattery, whether self-seeking or not. “Never accept flattery as though it were a compliment,” says Russell Lyne, “and never treat a compliment as though it were merely flattery.”

Handing someone a compliment must always be a serious act, considered and truly appreciative. Eleanor Hamilton offers this advice: “A compliment is a gift, not to be thrown away carelessly, unless you want to hurt the giver.”

Why is it a universal human need, then, to thrive on praise? Simply because to live happily and effectively as individuals we need a strong and vigorous self-esteem, and compliments nourish it as nothing else can ever do.

As Jo Coudert wisely tells us: “When someone is deprived of his self-esteem, he is deprived of the only thing that makes him a person worth loving. For one’s own benefit, if for no other reason, the effort should be to build self-esteem in the other, to confirm rather than to assault it. This is achieved, not by flattery, but by a generous appreciation of the other’s strengths and a generous de-emphasis of his weaknesses, by speaking of his good points and as rarely as possible about his bad ones. People who are good to each other make each other good.”

This vital self-esteem may be a species of self-love, but it is neither selfishness

nor conceit. “It is the self being strong enough to forget about the self and go out to others.” If we have a good and deep relationship with ourselves, then we shall have good and deep relationships with others, but not otherwise. Praise and encouragement are the twin fertilisers of everyone’s self-esteem. Without them, our very personality withers.

This is, of course, especially true between friends, and most of all in marriage, yet these are the areas where compliments are often sparsest. Fulton Oursler sums it up admirably: “The wife or husband who is alert to say the heartening thing at the right moment has taken out valuable marriage insurance. Women seem to have an instinct for such things; they look at life, so to speak, through their hearts.”

Why is it, then, as Maude Royden points out, that the closer the relationship, the fewer the words of genuine praise? Families in particular seem to feel it necessary to make a fetish almost of general denigration, a continual cutting down to size of every member in turn. Granted that those close to us are best qualified to notice if our heads start to swell; but the desire to stop that process at all costs makes family life a hotbed of criticism and a desert for praise.

After all, every human soul grappling with life has a right to expect the magic of the occasional compliment from those in closest relationship with him; yet if we are honest with ourselves we will confirm that the best words and acts of encouragement we have received have almost always come from outsiders. This clearly is wrong.

The more good we can find to say about anyone, close or distant, the more good that person will become. It is as simple—and as profound—as that. Certainly there is no better way of turning the noisy rattle of the world into music.



The
Rosicrucian
Digest
June
1976

Rosicrucian Activities Around the World



GRAND LODGE OFFICERS representing Grand Lodges of AMORC throughout the world recently assembled with the Supreme Grand Lodge Officers in special session. This assembly was held in the month of April in Rosicrucian Park. The purpose was the discussion of the Administration and furtherance of the activities of these Grand Lodges throughout the world.

Standing from left to right are Frater Edward van Drenthem Soesman, Grand Master of the Grand Lodge of the Netherlands, and Soror Soesman; Frater Roland Petterson, Grand Councilor of AMORC France, Switzerland; Grand Secretary of the French-speaking countries, Frater Christian Bernard; Frater Alden Holloway, Coordinator of Foreign Grand Lodge Activities; Imperator Ralph M. Lewis; Supreme Secretary Arthur Piepenbrink.

Seated, left to right, are Frater José Paulo, Grand Secretary-Treasurer of AMORC Brazil; Frater Irving Soderlund, Secretary-General of AMORC Sweden; Soror Gladys Lewis of the Supreme

Grand Lodge; Soror Maria Moura, Grand Master of AMORC Brazil; Frater Erwin Watermeyer, member of the Board of Directors, AMORC Germany; and Frater Wilhelm Raab, Grand Master, Grand Lodge of AMORC Germany. For enlarged photograph of group, see Frontispiece.



A recent distinguished Rosicrucian member visiting Rosicrucian Park was Frater S. T. Muna, former Premier of Cameroon, and current President of that country's National Assembly. Traveling on an official journey and meeting with other parliamentary officials to discuss world environmental problems, Frater Muna stopped off in San Jose to visit Rosicrucian Park and Officers of the Rosicrucian Order.

SOUTH AFRICA, CAPE TOWN—Southern Africa Regional Conclave—September 18-19, Good Hope Chapter, AMORC, Kinkle Way, under Newlands Bridge, Newlands, Cape Town. Grand Lodge will be represented by Frater Harry Bersok, Director of the Department of Instruction. For more information, please contact Mr. D. Rava, Conclave Secretary, P.O. Box 2080, Cape Town, 8000, Republic of South Africa.

ROSICRUCIAN DIRECTORY

A complete directory of all chartered Rosicrucian Lodges, Chapters, and Pronaoi throughout the world appears in this publication semiannually—in *February* and in *August*.

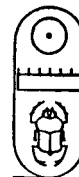



Is Man Subject to Solar Cycles?

DOES light exert a *strange influence* on man's mind? Are wars and large-scale political upheavals the result of subtle cosmic disturbances? Sun spots alter your radio reception—do they also produce aggravating effects upon your nervous system? You are being continually bombarded by invisible radiations from space. Learn about these mysterious energies and how they influence your thoughts and moods.

Free Manuscript

Merely subscribe or renew your subscription to the *Rosicrucian Digest* for one year—and ask for the *free* manuscript entitled "The Influence of the Sun on Human Affairs."** \$5.00* for each one-year subscription.

The ROSICRUCIAN DIGEST
San Jose, California 95191, U.S.A.

**This offer does not apply to members of AMORC, who already receive the *Rosicrucian Digest* as part of their membership.

*Foreign Currency Equivalents
£2.75 A\$4.00 NZ\$5.00
¥3.35 €6.25 R4.35

THE PALACE OF VERSAILLES

» » »

In this great complex of structures in which several kings of France once resided, many tragic events occurred. The palace was built by Louis XIV and is located near Paris. Adjoining it are magnificent gardens and fountains renowned throughout the world. The interior has been restored in the fashion of its past. It is from here that Marie Antoinette, wife of Louis XVI (1774-93), was led with other members of the royal family to be tried by the Revolutionaries and finally guillotined.

(Photo by AMORC)

ANCIENT JERICHO (overleaf)

Shown here are the walls of several cities of ancient Jericho built one upon the other. The most ancient structure is estimated to date even 3000 years before the civilizations of Egypt and Sumer. The most ancient city was located in an oasislike area with palms, rose trees, and grapevines in profusion. Beneath more recent structures, archaeologists have discovered fallen walls of the late Bronze Age which show destruction by burning and seem to corroborate the Biblical account that the city was invaded around 1400 B.C. by the Israelites and burnt by Joshua.

(Photo by AMORC)

**The
Rosicrucian
Digest
June
1976**

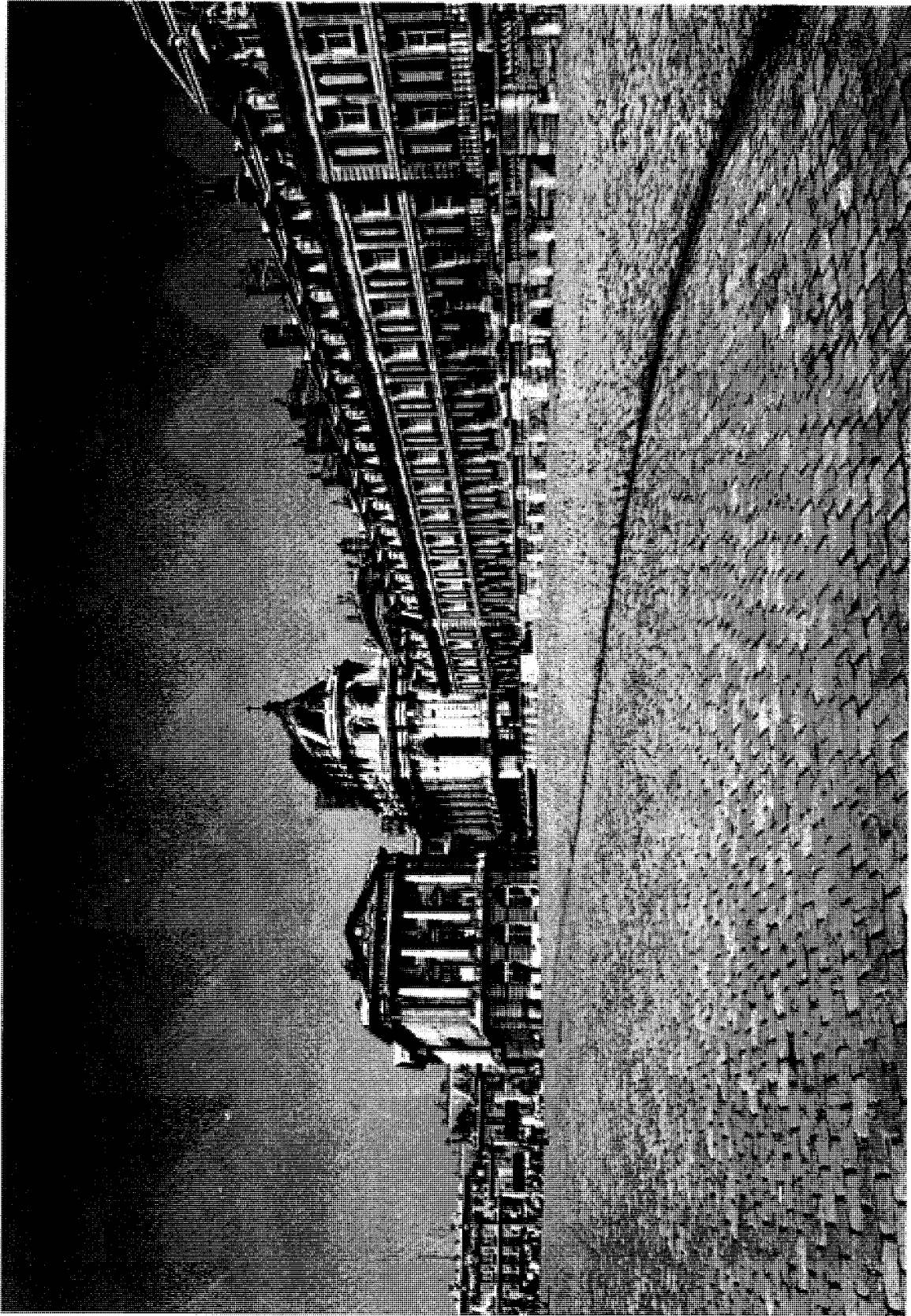

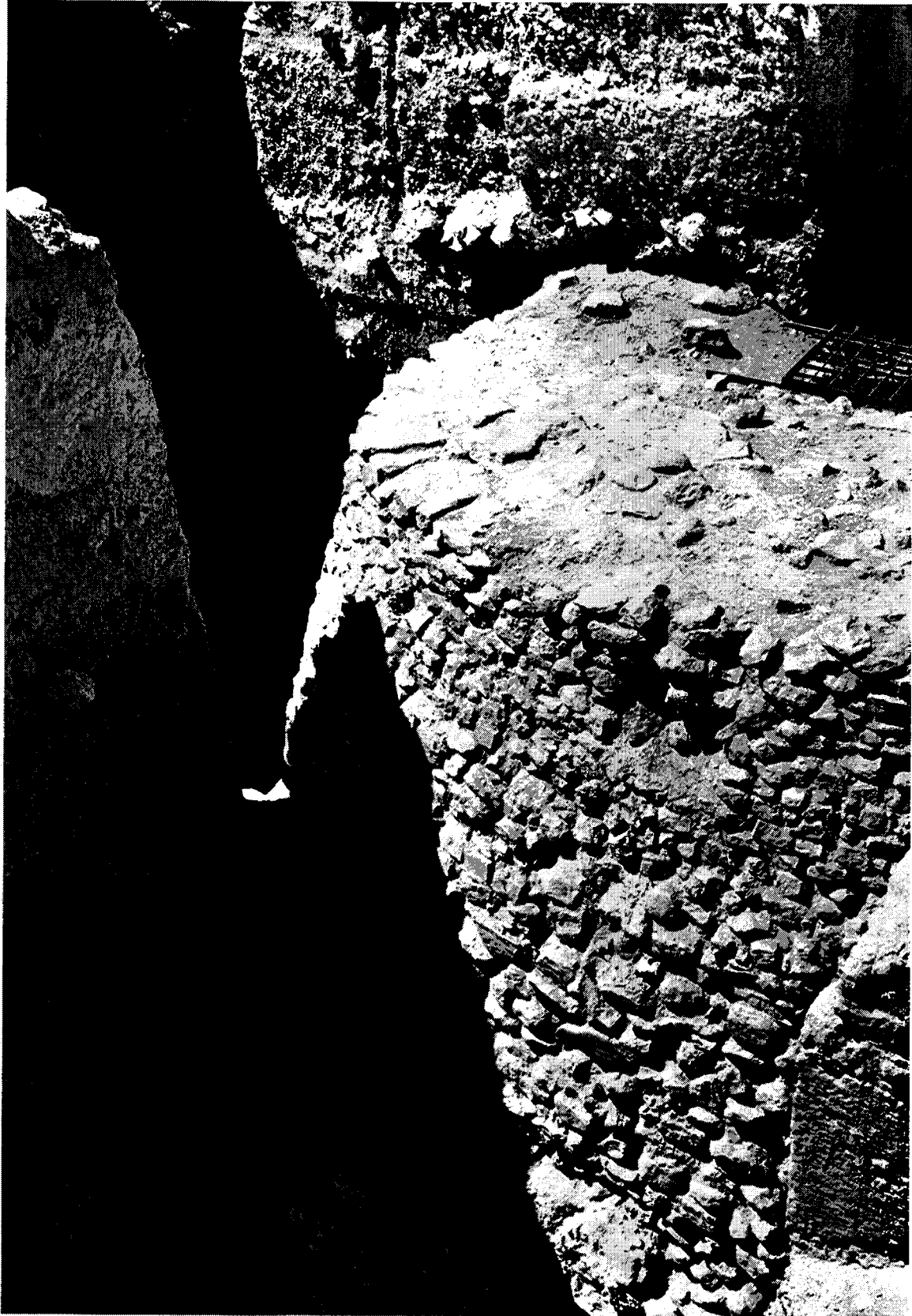

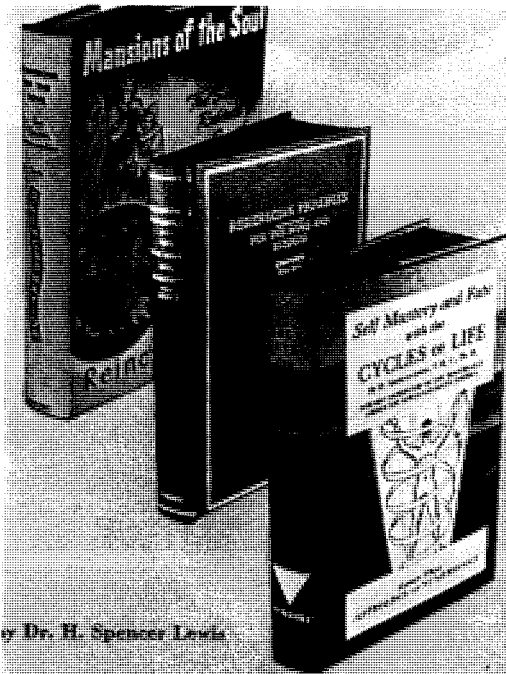

by Dr. H. Spencer Lewis

Three Books for Interesting Reading

Mansions of the Soul

This book reveals in an astounding manner the many facts to support reincarnation. Quotations from eminent authorities, from Biblical and Sacred works, substantiate this doctrine. This volume PROVES reincarnation.

This Book Explains . . .

All about the soul and its cycles of reincarnation. It tells you in plain and understandable language where the Mansions of the Soul are, and why the soul has these Mansions and what is accomplished in them.

Rosicrucian Principles for Home & Business

This volume contains such principles of practical Rosicrucian teachings as are applicable to the solution of the everyday problems of life. It deals exhaustively with the prevention of ill-health, the curing of many of the common ailments, and the attainment of peace and happiness.

The book points out the wrong and the right ways for the use of metaphysical and mystical principles in attracting business, increasing one's income, promoting business propositions, starting and bringing into realization new plans and ideas, and the attainment of the highest ambitions in life.

Self Mastery and Fate With the Cycles of Life

This book will give you a practical method to map the course of your life—hour by hour, day by day. No guesswork of indications, no phantasm. A simple, surprising survey, openly stating the marvelous mystical manifestations of the *cycles of life*, which enables every man or woman easily to learn more about the *fortunate and unfortunate* periods in each day. Here is an opportunity to be prepared for all the strange occurrences that perplex every human being. This book, *Self Mastery and Fate*, contains a system which time has shown has no equal in any form of astrology, numerology, or character reading.

Each Book is Priced at

Foreign Currency Equivalents
 £3.20 A\$4.60 NZ\$5.75
 ¥3.85 £7.20 R5.00

\$5.75

California residents please add 8% for sales tax.

Send your order to:

Rosicrucian Supply Bureau

San Jose, California 95191, U. S. A.



Esoteric Essays

Esoteric Essays consist of a simple presentation of particularly interesting subjects in the realm of metaphysics and mysticism. The essence of these age-old subjects is introduced for brevity and yet they are prepared in a manner which, it is hoped, will stimulate the reader to a more extensive inquiry and study of such channels of knowledge.

Now available are several titles. Additional titles will be announced later. These handy pocket-size booklets also make excellent gifts for interested friends.

- G-3 What is Karma?
- G-4 Reincarnation
- G-23 Meditation
- G-24 Color

75¢ each

Foreign Currency Equivalents
 £.40 \$3.20 NZ\$2.25
 ¥1.00 6.75 €1.65

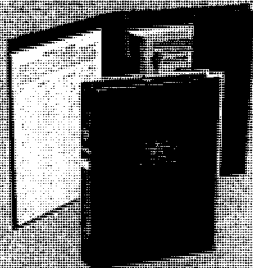

**Sold in Pairs
 Or in Packets Of 3
 Only
 Price For 2 \$7.75**

Foreign Currency Equivalents
 £1.35 \$10.80 NZ\$7.25
 ¥17.15 117.75 €4.25

Price For 3 \$10.45

Foreign Currency Equivalents
 £3.00 \$24.00 NZ\$16.45
 ¥212.75 1392.00 €57.15

Rosicrucian Lesson and Digest Binders

For Members Only

These new style lesson binders have been redesigned to make a more attractive and higher quality binder for your lessons.

Don't let your lessons become lost or jumbled. This expanding pocket-style binder will hold half a year's monographs. It is well made in black vinyl, stamped in gold with the name and symbol of the Order. It contains an index form for easy reference.

Digest Binders

We have now designed a very attractive binder of high quality for your Rosicrucian Digests. Each binder is beautifully made in red vinyl and will hold 12 issues of the Digest.

ANNOUNCEMENT: If you do not have an up-to-date illustrated catalogue and price list of all items available through the Rosicrucian Supply Bureau, please write to the address below for a free copy.

Send your order to:

California residents please add 6% for sales tax.

THE ROSICRUCIAN SUPPLY BUREAU

Rosicrucian Park • San Jose • California 95191 • U.S.A.

BRAVE NEW ERA

Every so often I receive letters from readers concerned over the latest medical or technological scares, wondering whether there is any truth to the claim that each time they use a deodorant spray they bring doomsday a little bit closer through the destruction of the atmospheric ozone layer by propellents used in some aerosol cans; or whether vitamin C can really: (a) cure; (b) help avoid; (c) do nothing (pick your own) in the war against the common cold. Usually answers to these queries are forthcoming from authorities through the media, or the fad dies down before anything can be researched and prepared for publication. The latest one of these, which I believed had died down a long time ago, is whether caffeine (and therefore coffee drinking) causes heart attacks and cancer.

There is a study which claims to have found statistical correlation between coffee drinkers and heart attack victims. This made a big splash in the news since according to it the possibilities of myocardial infarction (acute heart attacks) seem to increase by sixty to one hundred twenty percent if you drink five or more cups of coffee a day. This, added to another case study linking coffee drinking with bladder cancer, was widely circulated by certain religious groups, and this material, rewritten, reinterpreted, amplified, and otherwise augmented, found its way to the popular press and has been circulating ever since.

What are the facts in all this? Simply these: The study linking heart disease and coffee was completely discredited as it was carried out in a most unscientific way. It was made in 1973 by Dr. Herschel Jick, former director of the Boston Collaborative Surveillance program at Boston University. The aspect of the study that did not receive wide publicity was that Dr. Jick's control group was composed of hospital patients instead of healthy persons. These patients had survived heart attacks and there was no data on those who had died from them. Some researchers suggested the data could also be interpreted to show that coffee drinking helped some of them survive their heart conditions! Dr. Jick's results were unreproducible by other researchers using proper controls.

Coffee's supposedly cancer-producing characteristics were a result of a 1971 Harvard School of Health study. Dr. Philip Cole, head of the research team, was searching for a link between cancer and various substances, and the data showed that many of those suffering from bladder cancer were coffee drinkers . . . and also heavy smokers, users of cyclamates, alcoholics, etc.; but this part of the study was ignored by the anti-coffee groups. A new study carried out by Dr. Cole, focusing only on coffee, failed to

establish any correlation between cancer incidence and coffee use, heavy or otherwise.

The causes for heart disease are many. They are not only environmental, but may also be genetic, or a combination of both. A condition may be hidden, just waiting for some factor which in an otherwise normal person would do nothing, to trigger it into action. Medical science has made great strides in the treatment and prevention of these conditions, but there is still a very long road to be traveled, and all-encompassing statements in this regard should be viewed—regardless of who utters them—with at least polite skepticism.

Regarding cancer, things stand more or less the same as with heart disease. There are many promising theories, some very sound avenues of research, but barring some sort of an unexpected breakthrough, no quick answers. Research has shown one thing, however: a gross excess of practically anything tends to cause cancer, be it sunlight, alcohol, or even sugar; therefore, moderation in all things should be the password.

As to how many cups of coffee are too many, this varies according to the size of the cup and the strength of the brew. Three standard cups of standard strength coffee (there are various definitions of what the "standard" is), taken in quick succession contain enough caffeine to produce irritability, nervousness, headaches, etc. But people react differently to caffeine and some studies show that with others tension is reduced and headaches relieved by coffee.

In case you're wondering, the lethal dose for humans is ten grams of caffeine, so to reach the Great Beyond you would have to drink quickly some 100 cups of the stuff and, even if you could, it probably wouldn't work because caffeine does not accumulate in the human body, but is rapidly metabolized and excreted.

In moderate amounts coffee (as well as the other caffeine-containing substances like tea, cocoa, and cola drinks) acts as a mild stimulant, is not habit-forming like opiates and alcohol, and adds to social exchange during coffee breaks.

Some people feel they can't function without their morning cup, while others consider it a poison and its consumption something akin to suicide. Whichever band you may favor, the fact remains it is comforting to consider that there are still a few relatively harmless things left that can be enjoyed with a clear conscience during the course of this, our brave new era.—AEB

(This article is being offered as a point of news but does not involve AMORC, nor necessarily represent the organization's viewpoint)

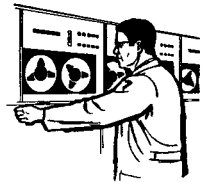
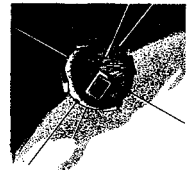
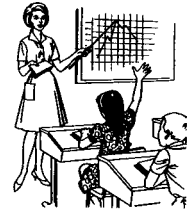
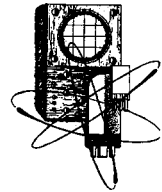

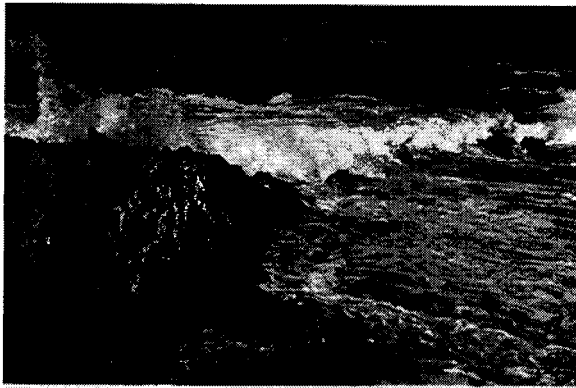

ODYSSEY

Scientist-President Part I

FREEDOM OF INQUIRY has always been valued by those seeking new knowledge and higher vistas for mankind. Thomas Jefferson (1743-1826) was such a seeker, and was guided by this principle throughout his life. Known in history as a founder and early leader of American democracy, it is less well known that the author of the **Declaration of Independence** was also a scientist very interested in finding out more about the world we live in.

A well-educated man, Jefferson took a special interest in science. With the mind of a natural scientist, he was exceptionally curious about the workings of nature, approaching his various investigations with an objective and open outlook. A passion for precise detail, meticulous notetaking, and complete objectivity (most of the time) were all part of Jefferson's special approach to the many things he was interested in. Away from public life and government duties, which took most of his time, Jefferson occupied precious hours in scientific investigation into an array of varying subjects including agriculture, architecture, meteorology, steam power, American Indian customs and languages, balloons, chemistry, and botany—to name just a few.

With his time devoted to both public service and scientific investigation, Jefferson placed himself in an unenviable position for his day. Science, then known as "philosophy," had a rather questionable reputation—a reputation that could hurt Jefferson—a well-known political figure. Many viewed scientists as enemies of religion, possessing dangerous radical ideas which threatened the established value system.

Jefferson's interest in new ideas, new inventions (some of which were his own), and belief in the necessity of free inquiry caused him to be disliked by many narrow-minded citizens. And of course political enemies made the most of Jefferson's "impractical and dangerous" philosophical bent. Others warned that governing a new nation and the pursuit of scientific interests could in no way mix. Fortunately, however, Jefferson had numerous admirers, both in the United States and abroad, and they rallied to his defense throughout his career. Among men of learning he was honored by serving as the President of the American Philosophical Society for seventeen years.

Jefferson found it difficult to understand those who disliked and feared science. As an optimist, believing in man's innate reason and moral sense, he desired more freedom from limiting ideas of the past—ideas which held mankind back. Advocating education for the masses, he saw science as a consciousness-raising tool for modern man. And because he believed in the necessity for scientists to inquire everywhere and arrive at independent conclusions—free from government interference—he saw democracy as the best form of government, permitting the full expression of individual human potentialities. Thus science would advance human happiness.

The practical and yet far-reaching ideas held dear by Thomas Jefferson are perhaps best expressed in his **Declaration of Independence**. A rereading of this document will prove both enlightening and inspiring.—RMT

